

## **SAFETY AND SECURITY OF THE PERSONAL BELONGINGS USING MICROCONTROLLER**

**Hamsa Fawaz Thanoon**

Assistant Lecturer, College of Electronics Engineering, University of Mosul

E-mail:hamsaf.thanoon@yahoo.com

(Received: 28/11/2013; Accepted: 2/3/2014)

### **ABSTRACT:**

Security systems are vital for protection of information and property which it is necessary for prevention them from theft or crime. The simplicity of design makes it compatible in different scenarios such as a home or commercial security system like datacenters and banks. In this experimental work it has been programmed the microcontroller 89C51, and connected it with other electronic components to economize a security of money cabinet. The assembly language was used to program this microcontroller to control for open and close operations of the money cabinet by using limited keys as password of known person. The alarm light emitting diode LED would light by pressing the false key then the camera would take the picture for this unknown person.

**Keywords:** microcontroller 89C51, security systems.

---

### **1. INTRODUCTION:**

Security and safety is one of the most talked of topics in almost every facet like surveillance, industrial applications, offices, and in general, in smart environments. To secure it against theft, crime, fire, etc. a powerful security system is required not only to detect but also pre-empt hazards. Conventional security systems use cameras and process large amounts of data to extract features with high cost and hence require significant infrastructures <sup>(1)</sup>.

The integrated circuit technology is the one of the most important fields of the electronics since it minimizes the area of the circuit, parasitic effects and the cost. Furthermore, these devices are more reliable than the circuits that are set up of the discrete components. Therefore, the interest in this subject is increasing day by day. In topic, a general-purpose 8-bit microcontroller is designed using Very Large Scale Integrated Circuit (VLSI) design methods <sup>(2)</sup>.

## **2. LITERATURE REVIEW:**

There are many experimental researches for the security system using microcontroller, it will be mentioned some of them as the following:

In 2009 <sup>(3)</sup>, Attaullah Khawaja designed low cost electronic system which can control different locking mechanisms. Hardware design of an electromechanical lock is also presented. Microchip Peripheral Interface Controller (PIC) microcontroller is the brain controlling all the operations. Low operating power consumption, small circuit, non-volatile memory operation using on-chip Electrically Erasable Programmable Read Only Memory (EEPROM), flexible mechanical design and user friendly interface are the salient features of this security system.

In 2011 <sup>(1)</sup>, Zamshed Iqbal Chowdhury et.al. developed of a low-cost security system using small (Pyroelectric Infrared) PIR sensor built around a microcontroller. The low-power PIR detectors take advantage of pyroelectricity to detect a human body that is a constant source of Passive Infrared (radiation in the infrared region). The system sensed the signal generated by PIR sensor detecting the presence of individuals not at thermal equilibrium with the surrounding environment. Detected the presence of any unauthorized person in any specific time interval, it triggers an alarm & sets up a call to a predefined number through a global system mobile (GSM) modem. This highly reactive approach has low computational requirement, therefore it is well-suited to surveillance, industrial applications and smart environments. Tests performed gave promising results.

In 2011 <sup>(4)</sup>, Rajesh Kannan Megalingam, et.al. deployed the home security system at the homes where elders live. This can also be installed at all homes where there is threat from robbery. This system automatically sent a short message system (SMS) or calls the police if the doors or windows are opened by an external person. The door breakage module informs the General Packet Radio Service (GPRS) modem about the theft attempt through a wireless interface. The GPRS modem calls for necessary help spotting the location. Through Person Identification Function (PIDF) which is part of Intelligent Wireless Home Security System (IWHSS), the elders can monitor the people outside the house and also talk with them through the intercom provided. Through this cost effective setup, the life of many elders can be saved even though they are living alone and their lives will not be in anymore danger.

In 2011 <sup>(5)</sup>, Xizi Li and Changyi Ji presented an industrial temperature measuring and monitoring system, which is based on 89C51 single chip microcontroller, and details the comparison between Formula method and Look-up Table method whose new algorithm and high precision has been emphasized. The system can measure real-time industrial temperature, store historical data and display temperature in digital and curve

diagram. MAX6675 is applied in temperature acquisition module, which simplifies the system design and improves measuring precision.

In 2012<sup>(6)</sup>, R. Ramaniet. al. designed and implemented a bank locker security system based on Radio-frequency identification (RFID) and Global System Mobile (GSM) technology which can be organized in bank, secured offices and homes. In this system only authentic person can be recovered money from bank locker. It had implemented a bank locker security system based on RFID and GSM technology containing door locking system using RFID and GSM which can activate, authenticate, and validate the user and unlock the door in real time for bank locker secure access. The main advantage of using passive RFID and GSM is more secure than other systems. This system consists of microcontroller, RFID reader, GSM modem, keyboard, and LCD, in this system The RFID reader reads the identified (id) number from passive tag and send to the microcontroller, if the Id number is valid then microcontroller send the SMS request to the authenticated person mobile number, for the original password to open the bank locker, if the person send the password to the microcontroller, which will verify the passwords entered by the key board and received from authenticated mobile phone. If these two passwords are matched the locker will be opened otherwise it will be remain in locked position, this system is more secure than other systems because two passwords required for verification. This system also creates a log containing check-in and check-out of each user along with basic information of user.

### **3. EXTERNAL PERIPHERALS:**

The 8051 microcontroller is an 8-bit microcontroller originally designed by Intel that consists of several components: a controller and instruction decoder, an Arithmetic and Logic Unit (ALU), 128 bytes of internal memory, up to 64 KB of external memory addressed by a 16-bit data pointer (DPTR) register, and up to 64 KB of external program memory or 4 KB of internal program memory read only memory (ROM). The 8051 also has 28 bytes of special function registers (SFRs), which are used to store system values such as timers, serial port controls, input/output registers, etc.<sup>(1)</sup>.

There are four ports designated as P<sub>1</sub>, P<sub>2</sub>, P<sub>3</sub> and P<sub>0</sub>. All ports 8-bit bi-directional, it has been used as both input and output ports. Except P<sub>0</sub> which needs external pull-ups, reset of the ports have internal pull-ups. When ones (1s) are written to these port pins, they are pulled high by the internal pull-ups and can be used as inputs. These ports are also bit addressable and so their bits can also be accessed individually.

The P<sub>0</sub> and P<sub>2</sub> are also used to provide low byte and high byte addresses, respectively, when connected to an external memory. Port 3 has multiplexed pins for special functions like serial communication, hardware interrupts, timer inputs and read/write operation from

external memory. The 8051 microcontroller has an inbuilt universal asynchronous receiver/transmitter (UART) for serial communication. It can be programmed to operate at different baud rates. Including two timers & hardware interrupts, it has a total of six interrupts<sup>(7)</sup>. The LCD and keypad connected to the microcontroller, to input the keys by keypad and show the results by LCD.

### **3.1 LIQUID CRYSTAL DISPLAY (LCD):**

LCD Background: Frequently, an 8051 program must interact with the outside world using input and output devices that communicate directly with a human being. One of the most common devices attached to an 8051 is an LCD display. Some of the most common LCDs connected to the 89C51 are 16x2 and 20x2 displays. This means 16 characters per line by 2 lines and 20 characters per line by 2 lines, respectively<sup>(8)</sup>.

### **3.2 KEYPAD:**

There were using 4x3 keypad in this work. A keypad is simply an array of push buttons connected in rows and columns, so that each can be tested for closure with the minimum number of connections. The key press is scanned by bringing each X row low in sequence and detecting a Y column low to identify each key in the matrix<sup>(9)(10)</sup>.

### **3.3 CAMERA:**

A cabin-mounted CMOS camera (the C238R) will be used for image capture. It will provide 640x480 resolutions and will implement Joint Photographic Experts Group (JPEG) compression, allowing to take red green and blue (RGB) images. It will controlled by the microcontroller via a serial port (15200 8-N-1). Additionally, it will transfer data to the microcontroller after image acquisition and compression is completed.<sup>(11)</sup>

## **2. EXPERIMENTAL WORK**

It has been programmed the microcontroller 89C51 using assembly language, then connecting this microcontroller with keypad, LCD and LED diode. The keypad has been used to enter the codes, the LCD to show the input codes and results and the LED diode to light for open, close or alarm. It has been used the camera in internal circuit but don't used it in experimental circuit, this camera used for other protection to capture the picture for unknown person after entering all false attempted for input the money cabinet. In this manner it has been protected the system by using three error attempt to open the money cabinet, after ending the last error attempt for opening, the alarm led diode would be on and the web camera would be on and it has been taken the picture for this unknown person (this web camera used in circuit diagram and flow chart for adding the security but not used in experimental circuit). The circuit diagram connecting in this search as shown in Figure (1):

### **3. RESULTS & DISCUSSION**

The results were concluding the codes were programmed using assembly language. Codes for open, close the money cabinet, and error code for alarm, there were four codes for open the money cabinet (1, 3, 5, 0). When pressing number '1' in keypad, it has been compare this key with the code in microcontroller, at this moment this key was conformable with the code stored in the microcontroller, it has been continued to fourth true key. Number '3' was the second code, number '5' was the third code and number '0' was the fourth code, there were programmed delay between the codes at 0.5sec, the green led diode was lighting. The sign '#' for closing the money cabinet, the yellow led diode was lighting. If pressing three errors trying for open the money cabinet, the red led diode was lighting. This means using 'alarm' buzzer or any sound and it has been taking the picture for known and unknown person by using web camera, it has been on for 0.5 minutes, and then would be off.

To explain the experimental work, it has been necessary to show the flow chart as shown in figure (2). The experimentally circuit was using for the search as shown in figure (3).

### **4. CONCLUSIONS:**

In this paper, there was showing the security of money cabinet, it has been programmed the microcontroller 89C51 using assembly language. This program has been used to control to open and close the money cabinet by limited keys by own person, and take the picture for this person using web camera. If any person want to open it and press the false key, the alarm LED diode would lighted, and take the picture for the unknown person by web camera also. In this manner, it has been protected the money cabinet from any person unwanted to open it.

### **REFERENCES:**

- 1) Chowdhury Z. I., Imtiaz M. H. and et. al., "Design and Implementation of Pyro electric Infrared Sensor Based Security System Using Microcontroller", 978-1-4244-8943-5/11/\$26.00IEEE, 2011.
- 2) Yates and Nigel, "Anglican resurgence under W. F. Hook in early Victorian Leeds. Church life in a Nonconformist town, 1836–1851.By Harry W. Dalton.", Journal of ecclesiastical history, Volume 55 Issue, pp.425-445, 2004.
- 3) Khawaja A., "Firmware and Hardware Design of a Novel Door Locking System", 2009.
- 4) Megalingam R. K., Nair R. N. and et. al., "Low Power, Intelligent, Wireless, Home Security System for the Elderly People", Journal of IEEE, pp.320-324, 2011.

- 5) 5-Li X. and Jiao C., “Water Conservancy Monitoring System Based On Wireless Sensor Network”, 978-1-4244-9439-2/11/\$26.00 IEEE, 2011.
- 6) 6-Ramani R., Valarmathy S., “Bank Locker Security System based on RFID and GSM Technology”, International Journal of Computer Applications (0975 – 8887) Volume 57–No.18, November 2012
- 7) 7- www.datasheetcatalog.com, “8-bit Microcontroller with 4 K Bytes Flash AT89C51”.
- 8) 8-YangW. and et. al., “Application and Design of Automation Communication Devices-A Novel Design of Digital Doorbell”, 978-1-61284-486-2/111\$26.00 IEEE, 2011.
- 9) 9-Saini S., Suri C. R., “Design and Development of Microcontroller Based Auto-Flow Assembly for Biosensor Application”, International Journal of Computer Applications (0975 – 8887) Volume 6–No.1, September 2010.
- 10) 10-HariPrasadi S. A., Kariyappa B. S., Nagaraj R., Thakur S. K., “Micro Controller Based Ac Power Controller”, Wireless Sensor Network, 2009, 2, 61-121 by Scientific Research, pp:76-81.
- 11) 11-Henderson R., “CMOS Digital Camera Controller and Frame Capture Device”, May 26,

FIGURES AND FLOWCHART:

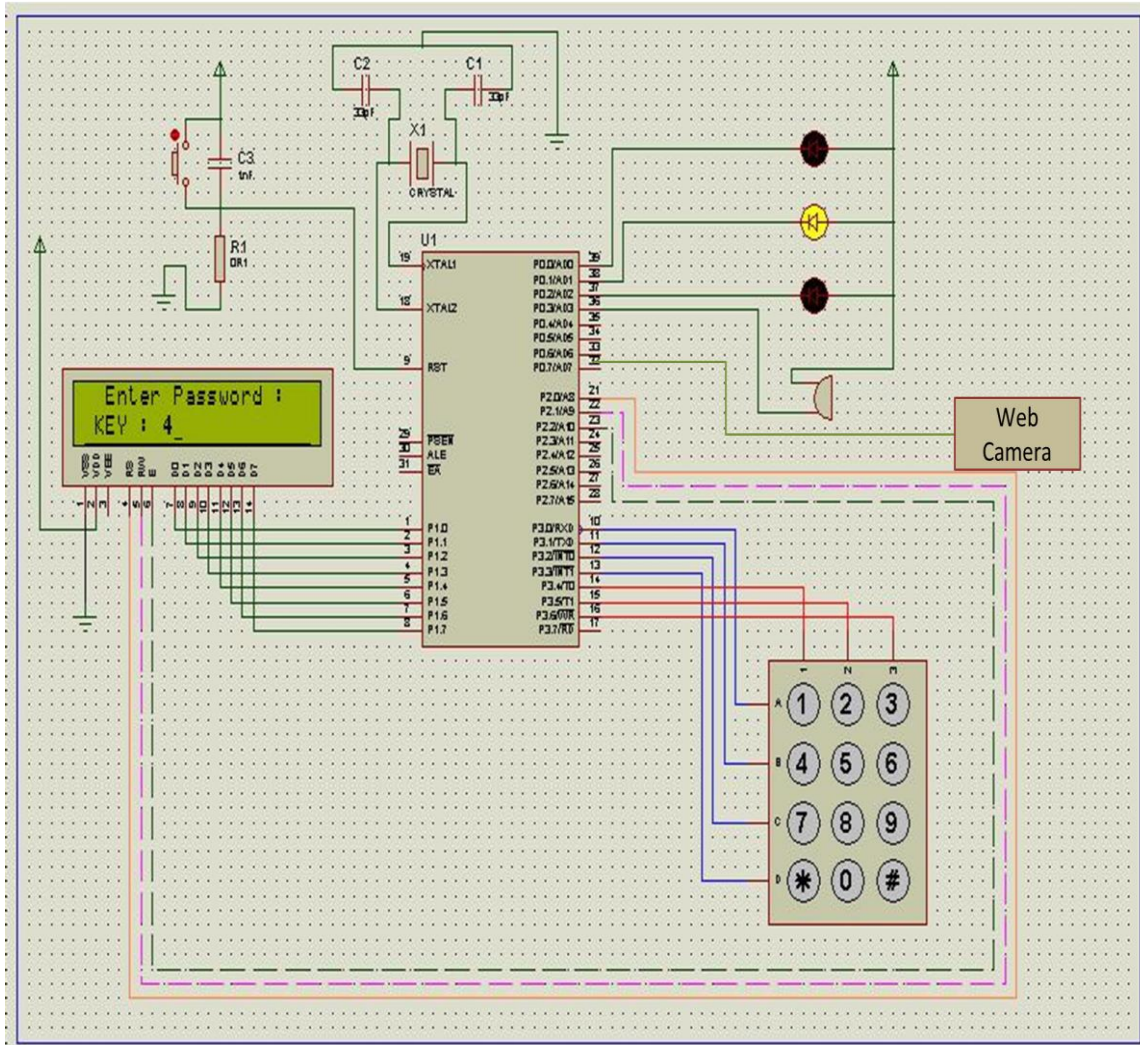

Figure (1): the circuit diagram of the security system

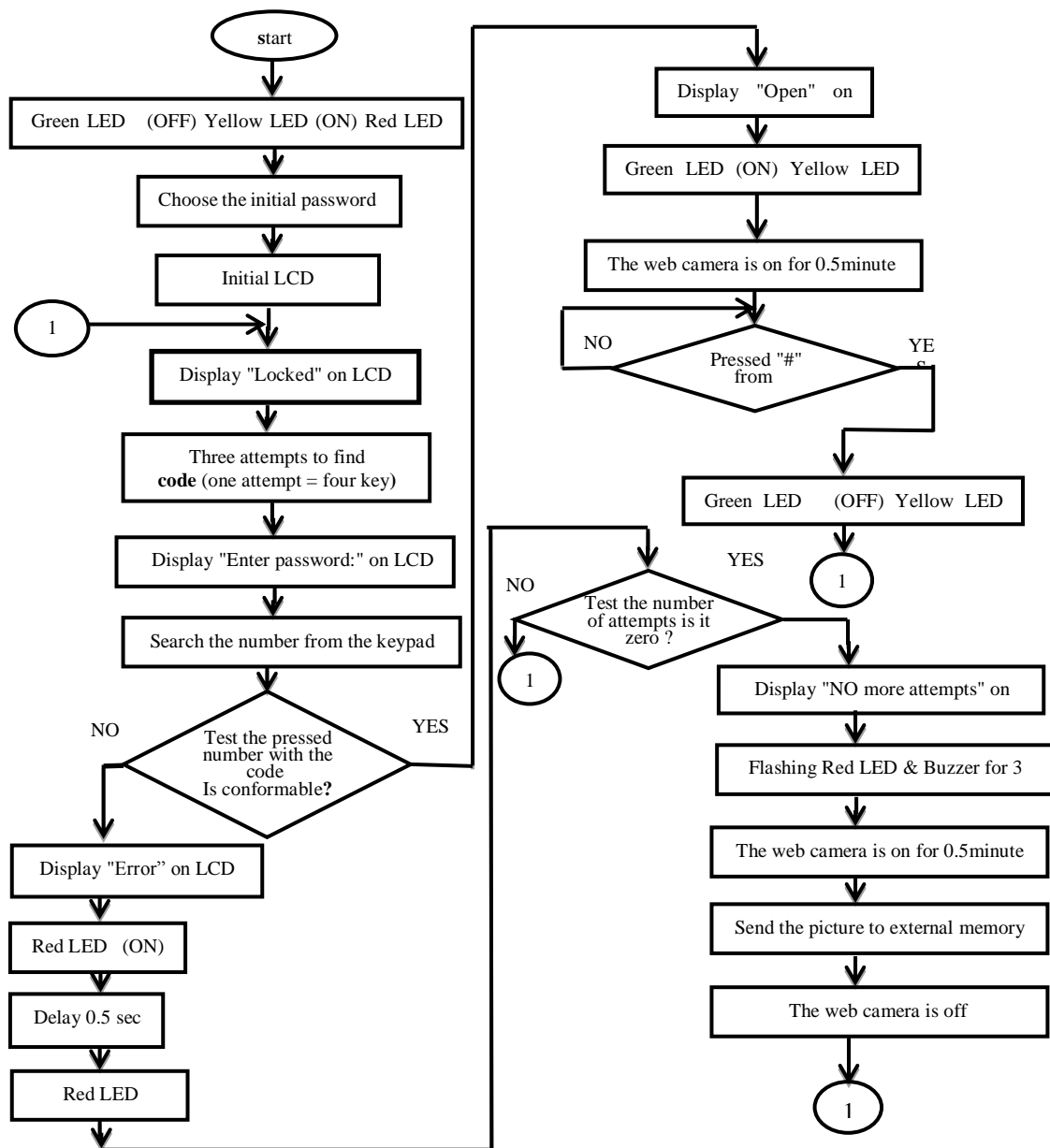

Figure (2): Flow chart of experimental work.





**Figure (3):** The experimental circuit of the security safety system.

## سلامة و أمن الممتلكات الشخصية باستخدام المسيطر الدقيق

همسة فواز ذنون

مدرس مساعد

كلية هندسة الالكترونيات / جامعة الموصل

### الخلاصة:

أنظمة الأمان أمر حيوي لحماية المعلومات والملكية وضرورية للوقاية من السرقة أو الجريمة. أن البساطة في تصميم أنظمة الحماية من الممكن إن يجعلها متوافقة للأغراض المنزلية أو التجارية المختلفة مثل مراكز البيانات و البنوك. يتضمن هذا البحث العملي برمجة المسيطر الدقيق 89C51 بربط هذه الشريحة مع أجزاء الكترونية أخرى لتوفير الحماية لحافظة النقود. استخدمت لغة التجميع لبرمجة هذه الشريحة للسيطرة على عملية فتح وغلق حافظة النقود من خلال استخدام مفاتيح محددة كرمز للمرور من قبل شخص معروف. إن الدايد الضوئي الخاص بالإنذار سيضيء عند الضغط على المفتاح الخاطئ وعندها ستقوم الكاميرا بأخذ صورة للشخص الغير معروف.

الكلمات الدالة: المسيطر الدقيق 89C51، أنظمة الحماية.