

## **DESIGN AND SIMULATION OF ASK 31 CHANNEL FREQUENCY HOPPING SPREAD SPECTRUM (FH/SS) TRANSCIEVER SYSTEM USING CONTIGUOUS BAND PASS FILTER BANKS**

**Khalid Awaad Humood<sup>1</sup> and Ali Abass Ali<sup>2</sup>**

<sup>(1)</sup>Engineering College , Diyala University

<sup>(2)</sup>Electrical & Electronic Engineering Dept., Al-Asraa University, Amman-Jorden

**ABSTRACT:-** This paper propose a design and simulation of Amplitude Shift Keying (ASK ) 31 channel frequency hopping spread spectrum (FH/SS) transceiver system. The proposed design is implemented using Matlab/Simulink package. There are many available synchronization techniques that can be used in frequency hopping spread spectrum (FH/SS) transceiver system most of these techniques require complex search operation and hence need complex hardware. In this paper a contiguous parallel digital band pass filter (BPF) banks for 31 channel FH/SS transceiver system has been designed and implemented successfully in real time using Matlab /Simulink. This designed bank of digital filters is used as a new, simple and efficient approach for synchronization of the system. This proposed system can be used to transmit and receive digital information with a data rate of 160 k bit /sec for frequency hopping rate of 160 k hop/sec and spread the transmitted data in the high frequency (HF) band, 18.6 MHz (3-21.6 MHz). Two models of jamming: multi-tone jamming (MTJ) and hopper jamming (HJ) were designed and simulated with and without the presence of Additive White Gaussian Noise (AWGN) to test the proposed design system . The obtained results proved that the proposed system passed these tests successfully.

**Keywords:-** FH/SS, ASK, Contiguous BPF, Noise and Jamming.

---

### **1. INTRODUCTION**

In the recent years, frequency hopping spread spectrum (FH/SS) communication system has played a growing role in modern communication systems from military to commercial application. The spread spectrum refers to the class of digital modulation that produce

bandwidth must be at least 10 to 100 time, the information rate must be independent of information bit rate <sup>(1, 2, 3)</sup>. In FH/SS, the spectrum of data modulated carrier is to change the frequency of the carrier periodically, each carrier frequency is chosen from a set of frequency [(2k-1), k is an integer number] which are spaced approximately the width of data modulation spectrum a part.

The spreading code in this system does not directly modulate the data modulated carrier but it is used to control the sequence of carrier frequencies. Because the transmitted signal appears as a data modulated carrier which is hopping from one frequency to the next, (FH spreader) this type of spread spectrum is called frequency hopping spread (FH/SS) <sup>(1)</sup>.

In the receiver side, de-spreader removes FH by mixing with received signal <sup>(4,5)</sup>. The synchronization is achieved by using new simple and efficient approach by means of using digital band pass filter banks (31 digital BPF). The situation of these filters are in receiver side of the system. In this paper wireless frequency hopping communication system have been designed and simulated for transmitting and receiving information with data rate up to 160 kb/sec. Amplitude Shift Keying (ASK) was used in this design for simplicity modulating and demodulating of transmitting information. The performance of any digital system is the measuring of Bit Error Rate (BER). These performance of FH /SS is examined under Additive White Gaussian Noise (AWGN) and different types of jamming.

The system spread the transmitted data in the high frequency (HF) bandwidth (BW) of 18.6 MHz (3-21.6) MHz, using 31 channels to hop over them in FH, with hopping rate of 1 /160 k hop /sec.

This design is implemented using MATLAB-Simulink which is an attractive simulation tools that provides the designer many facilities to rapidly design, implement and test the desired system. Also it gives the designer clear imaginations to the system parameters which required completing the design.

## **2. DESIGN OF CONTIGUOUS DIGITAL BPF BANKS**

Parallel contiguous Band Pass (BP) filters are designed and simulated. This design is used in FH/SS receiver system to achieve synchronization. There are two main classes of digital filters: Finite Impulse Response (FIR) and Infinite Impulse Response (IIR). In this paper FH/SS transceiver system. IIR filter is used because this type needs less number of coefficients and order than FIR <sup>(6)</sup>. Also IIR is sensitive to number coefficient and is not suitable for perfect linear phase response <sup>(7, 8)</sup>. The design of a digital filter is a task of

determining a transfer function (TF) which is a rational function in Z-1 in the case of recursive (IIR) filters. This TF function must meet certain performance specification. The designed individual BPF of the system is considered as TF with zeros and two conjugate poles are shown in Figure (1).

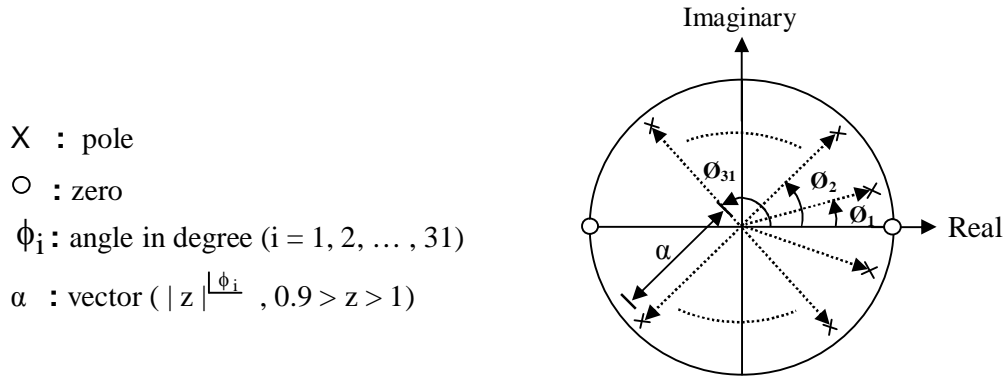

**Fig. (1) : Pole zero configuration for the designed BPF banks**

Then the TF of proposed designed for BPF banks is given as follow:

$$H(Z) = \frac{1 - Z^{-2}}{(1 - \alpha e^{j\phi})(1 - \alpha e^{-j\phi})} \tag{1}$$

$$\phi_i = \omega_{ci} T_{si} \tag{2}$$

Where:

$\omega_{ci}$  : center frequency (radian per second), ( $i = 1, 2, \dots, 31$ )

$T_{si}$  : sampling time, ( $i = 1, 2, \dots, 31$ )

From equation (1):

$$H(Z) = \frac{(1 - Z^{-1})(1 + Z^{-1})}{1 - 2\alpha \cos \phi_i Z^{-1} + \alpha^2 Z^{-2}} \tag{3}$$

The general recursive filter TF can be given by the following formula <sup>(9)</sup>.

$$H(Z) = \left( \sum_{k=0}^L b_k Z^k \right) / \left( 1 + \sum_{k=1}^R a_k Z^k \right) \tag{4}$$

where:

L and R: are integer numbers and must satisfy the inequality  $L \leq R$ .

$a_k$  and  $b_k$  are coefficient numbers.

By using MATLAB-Simulink version 7 and depending on equation (3), the IIR second order Butterworth BPF01 with ( $f_L = 3$  MHz,  $f_H = 3.6$  MHz,  $f_c = 3.3$  MHz and  $f_S = 60$  MHz) have been designed and so for the others BPFs. Its realization is shown in Figure (2) and the magnitude response and pole zero configurations of IIR second order Butterworth BPF01 for ASK FFH/SS transceiver system specified ( $f_L = 3$  MHz,  $f_H = 3.6$  MHz,  $f_c = 3.3$  MHz and  $f_S = 60$  MHz) using contiguous technique are shown in Figures (3) and (4) respectively.

An important special case that is used as a building block occurs when  $L = R = 2$ . Thus  $H(z)$  is a ratio two quadratics in  $z^{-1}$ , called a biquadratic section, and given by:

$$H(Z) = \frac{(b_0 + b_1 Z^{-1} + b_2 Z^{-2})}{1 + a_1 Z^{-1} + a_2 Z^{-2}} = \frac{b_0 ((1 + (b_1/b_0)Z^{-1} + (b_2/b_0)Z^{-2}))}{1 + a_1 Z^{-1} + a_2 Z^{-2}} \quad (5)$$

The direct form II and alternative realization of the biquadratic  $H(z)$  are shown in Figures (5) and (6). The alternative realization has been shown to be useful for amplitude scaling for improving performance of filter operation.

### **3. DESIGN OF PARALLEL CONTIGUOUS IIR 2ND ORDER BUTTERWORTH BPF BANKS FOR ASK FH/SS SYSTEM.**

The proposed system is a design of contiguous parallel second order Band Pass (BP) filters.

In section (2) the design of individual IIR second order Butterworth BPF is done. The proposed system needs to design contiguous parallel IIR second order Butterworth BPF banks as shown in Figures (7) and (8) using MATLAB-Simulink, which consists of 31 filters. Table (1) shows the TF for each filter which is found by the same procedure as in section (2). In this proposed system, the center frequency ( $f_c$ ) of each filter is shown in Table (2). The relation between  $f_c$ ,  $f_H$  and  $f_L$  is <sup>(9,10)</sup> :

$$f_c = (f_H + f_L) / 2 \quad (6)$$

where:

$f_c$  : center frequency,  $f_H$  : 3dB band stop frequency,  $f_L$  : 3dB band pass frequency.

In this proposed design, the transmitter is designed to transmit the information with data rate  $(1/T_b)$  equal 200 k bit /sec.

$$\frac{1}{T_b} = 200 \text{ K bits / sec}$$

where:

$$\frac{1}{T_b} : \text{data rate.}$$

The bandwidth of each filter is approximately twice of data rate  $(R_b)^{(11)}$ .

$$R_b = 1/T_b \tag{7}$$

$$\Delta F = (2/T_b) + f_g \tag{8}$$

where:

$\Delta F$  : 3dB bandwidth of BPF and  $f_g$  : guard band.

$$f_g = R_b / 2 \tag{9}$$

$$B_{ss} = (2^n - 1) \Delta F \tag{10}$$

where:

BSS: spread spectrum bandwidth.

n: integer number (number of D-Flip Flop of the Pseudo Noise (PN) code).

The design steps of this contiguous filters type are the same as those stated in section (2). Figure (9) shows the distribution of the frequencies over the ASK FH/SS transceiver system band (3MHz – 21.6MHz) used in this system). Figures (10) and (11) show the magnitude response and pole zero configurations respectively for BPF31 ASK FH/SS transceiver system specified ( $f_L = 21$  MHz,  $f_H = 21.6$  MHz ,  $f_s = 60$  MHz,  $f_c = 21.3$  MHz), using contiguous technique.

#### 4. PROPOSED DESIGN OF 31 CHANNEL ASK FH/SS TRANSCIEVER SYSTEM USING CONTIGUOUS BPF BANKS

Transceiver system using contiguous BPF rate is designed and simulated for thirty one channels ASK FH/SS with hopping rate of 160 k hop/sec and 160 k bit/sec data rate using contiguous IIR Butterworth BPF banks .

The block diagram of proposed system for contiguous IIR second order Butterworth BPF banks for ASK FFH/SS transceiver systems is shown in Figure (13) and it is implemented using MATLAB-Simulink version 7. This contains, the transmitter, transmission channel, contiguous digital BPF banks and receiver<sup>(12, 13)</sup>.

#### **a. The Transmitter**

The transmitter contains: data generator, spread code generator, serial/parallel converter, Direct Digital Frequency Synthesizer (DDFS), mixer (spreading ASK signals) and digital High Pass Filter (HPF).

#### **b. Transmission Channel**

Figure (12) shows block diagram of transmission channel that used in the proposed transceiver system. It contains Additive White Gaussian Noise Channel (AWGN) Multi tone Jamming (MTJ) and Hopper Jamming (HJ) (12).It has been used as a path between the two side of transceiver system.

#### **c. The Receiver**

As shown in block diagram of Figure (13), the receiver side which contains, bank of parallel digital BPFs, spread code generator, serial/parallel converter, DDFS, mixer (de-spreading), ASK demodulator, error rate calculation. Digital HPF is the same as that of the transmitter, it is used to reject the unwanted signal before de-spreading.

Implementation of bank of parallel digital BPF is shown in Figures (8,9) which contains 31 parallel, second order digital BPFs. The center frequency ( $f_c$ ) of each filter which is shown in Table (2) for contiguous technique.

## **5-SIMULATION RESULTS**

The performance of digital system can be evaluated by measuring the Bit Error Rate (BER) (14). Moreover in this work the effect of the noise (AWGN) and jamming (MTJ,HJ) to the ASK FH/SS transceiver system using contiguous technique are studied.

### **5.1 Effect of AWGN**

During simulation process and after 0.62 ms simulation time the number of bits is 10000 bits, if different values of SNR in dB are taken from AWGN block for each run

and calculate BER by using error rate calculation from communication block set, the results of these calculations are shown in Figure (14) for ASK FH/SS transceiver system using contiguous technique. The process gain (GP) in dB, can be calculated by using the following equation (12).

$$G_P = \frac{B_m \times 2^n - 1}{B_m} = 2^n - 1 \quad , \quad G_P (dB) = 10 \log(2^n - 1) = 10 \log 31 = 14.9 \text{ dB}_m \text{ , for } n=5$$

Where:

$B_m$  : message bandwidth

It is clear that from Figure (14), the BER performance for ASK FH/SS transceiver using contiguous technique is done correctly.

## 5.2 Effect of Jamming

The proposed system is tested under the following types of jamming:

### A- Effect of Multi-Tone Jamming (MTJ)

Different values of signals are taken of MTJ to obtain many values of Signal to Jamming Ratio (SJR) in dB and reading the corresponding BER by using error rate calculation block from communication block set, during the simulation process after 0.62 ms simulation time, the number of bits is 10000 bits for each run. The results of these calculations are shown in Figure (15) which shows the relationship between BER and SJR (dB) FH/SS transceiver system under MTJ using contiguous technique. It is clear that ASK FH/SS transceiver system under MTJ using contiguous technique has better BER performance compared with other type of jamming such as hopper jamming. That means the designed system work correctly and passed previous test successfully.

### B. Effect of Hopper Jamming (HJ)

The hopper jamming (HJ) has a severed effect than that of MTJ. Similarly the calculation of the effect of this type is done by running the system with simulation time of 0.62 ms to get 10000 bit for each run in order to calculate the BER. The results of these calculations are shown in Figure (16) which shows the relationship between BER and SJR (dB) FH / SS transceiver system under HJ using contiguous technique.

It is clear that the BER for ASK FFH/SS transceiver contiguous technique has less performance than the other type of jamming. This means that the proposed designed system work correctly and passed all tests successfully.

## 6. CONCLUSIONS

The proposed designed system had been passed different tests. That mean it work correctly due to successful results.

Because the proposed designed system is operated successfully, this work can be implemented by using Field Programmable Gate Array ( FPGA ) .

The new approach of synchronization which applied in this proposed designed system is succeeded due to the results obtained.

The designed system can be modified to transmit digital information with high data rate by changing the parameters of digital filters such as  $f_c$  , $f_L$  , $f_H$  and delay time.

High BER performance can be obtained by using long PN code and Frequency Shift Keying (FSK) or Phase Shift Keying (PSK) for the proposed designed system.

## REFERENCES

1. R. E.Zimmer and R.L.Peterson, “Digital Communication Spread Spectrum System”, Macmillan Publishing Company,1985.
2. C.W.Leon, “Digital and Analog Communication System”, 5th ed.,prentice Hill, Inc, 1997.
3. H.N.AL-shammary, “Design and Implementation of Direct Sequence Spectrum System Using Field Programmable Gate Array”, Msc. Thesis, Department of Electrical Eng., University of Technology, 2004.
4. J.R.Smith, “Modern Communication Circuits”, Second Edition, McGraw-Company, 1988.
5. T.S.Rappaport, “Wireless Communications Principle and Practice”, Second Edition, prentice-Hall, Inc, 2000.
6. S.K.Mitra, “Digital Signal Processing: A Computer-Based Approach”, McGraw-Hill, 1998.
7. C. Marven and G.Evers, “A Simple Approach to Digital Signal Processing”, John Wiley and Sons, Inc., 1996.
8. C. T. Ghfn, “Digital Signal Processing”, Oxford University Press, Inc., 2001.
9. L. C. Ludeman. “Fundamentals of Digital Signal Processing”, Harper and Row, publishers, Inc.,2001.



10. E. Strom, and T.Ottosson, “An Introduction to Spread Spectrum System ,, Technical Report Department of Signal and System , Chalmers University of Technology ,SE-4296 Goteborg, Sweden,2nd Corrected Printing , January ,7, 2004.
11. Don Torrieris , “ Principle of Spread Spectrum Communication Systems,, United State of America Springer , 2005.
12. K.A.Humood,“ Design& Simulation of Digital Band Pass Filter Banks For Frequency Hopping Spread Spectrum System,, PhD. Thesis, University of Technology, ALRasheed College of Engineering and Science, Electrical and Electronic Engineering Department, 2007.
13. “Simulink Block Library of The Communication Tool Boxes Reference”, The Math Work Inc. 2002.
14. NIIT, “Introduction to Digital Communication Systems”, Prentice-Hall of India Private Limited, 2004.

**Table (1):** The TF of Contiguous IIR second order Butterworth BPF banks .

Filter	Numerator	Denominator
BPF01	$1-Z^{-2}$	$1- 1.825327310364317 Z^{-1} + 0.939062505817493 Z^{-2}$
BPF02	$1-Z^{-2}$	$1- 1.780462134788994 Z^{-1} + 0.939062505817492 Z^{-2}$
BPF03	$1-Z^{-2}$	$1- 1.728570288583437 Z^{-1} + 0.939062505817493 Z^{-2}$
BPF04	$1-Z^{-2}$	$1- 1.669856565157487 Z^{-1} + 0.939062505817493 Z^{-2}$
BPF05	$1-Z^{-2}$	$1- 1.604552680763758 Z^{-1} + 0.939062505817493 Z^{-2}$
BPF06	$1-Z^{-2}$	$1- 1.532916359969485 Z^{-1} + 0.939062505817492 Z^{-2}$
BPF07	$1-Z^{-2}$	$1- 1.455230318635282 Z^{-1} + 0.939062505817492 Z^{-2}$
BPF08	$1-Z^{-2}$	$1- 1.371801148064918 Z^{-1} + 0.939062505817492 Z^{-2}$
BPF09	$1-Z^{-2}$	$1- 1.282958105079473 Z^{-1} + 0.939062505817493 Z^{-2}$
BPF10	$1-Z^{-2}$	$1- 1.189051812581083 Z^{-1} + 0.939062505817493 Z^{-2}$
BPF11	$1-Z^{-2}$	$1- 1.090452875804537 Z^{-1} + 0.939062505817492 Z^{-2}$
BPF12	$1-Z^{-2}$	$1- 0.987550419707721 Z^{-1} + 0.939062505817492 Z^{-2}$
BPF13	$1-Z^{-2}$	$1- 0.880750553273190 Z^{-1} + 0.939062505817493 Z^{-2}$
BPF14	$1-Z^{-2}$	$1- 0.770474766781543 Z^{-1} + 0.939062505817493 Z^{-2}$
BPF15	$1-Z^{-2}$	$1- 0.657158268381848 Z^{-1} + 0.939062505817492 Z^{-2}$
BPF16	$1-Z^{-2}$	$1- 0.541248266523904 Z^{-1} + 0.939062505817493 Z^{-2}$
BPF17	$1-Z^{-2}$	$1- 0.423202205030802 Z^{-1} + 0.939062505817492 Z^{-2}$
BPF18	$1-Z^{-2}$	$1- 0.303485957777140 Z^{-1} + 0.939062505817492 Z^{-2}$
BPF19	$1-Z^{-2}$	$1- 0.182571990097678 Z^{-1} + 0.939062505817492 Z^{-2}$
BPF20	$1-Z^{-2}$	$1- 0.060937494182508 Z^{-1} + 0.939062505817492 Z^{-2}$
BPF21	$1-Z^{-2}$	$1+0.060937494182508 Z^{-1} + 0.939062505817492 Z^{-2}$
BPF22	$1-Z^{-2}$	$1+0.182519900976780 Z^{-1} + 0.939062505817492 Z^{-2}$
BPF23	$1-Z^{-2}$	$1+0.303485957777140 Z^{-1} + 0.939062505817492 Z^{-2}$
BPF24	$1-Z^{-2}$	$1+0.423202205030802 Z^{-1} + 0.939062505817493 Z^{-2}$
BPF25	$1-Z^{-2}$	$1+0.541248266523903 Z^{-1} + 0.939062505817492 Z^{-2}$
BPF26	$1-Z^{-2}$	$1+0.657158268381847 Z^{-1} + 0.939062505817492 Z^{-2}$
BPF27	$1-Z^{-2}$	$1+0.770474766781542 Z^{-1} + 0.939062505817492 Z^{-2}$
BPF28	$1-Z^{-2}$	$1+0.880750553273190 Z^{-1} + 0.939062505817492 Z^{-2}$
BPF29	$1-Z^{-2}$	$1+0.987550419707721 Z^{-1} + 0.939062505817492 Z^{-2}$
BPF30	$1-Z^{-2}$	$1+0.090452875804536 Z^{-1} + 0.939062505817492 Z^{-2}$
BPF31	$1-Z^{-2}$	$1+1.189051812581083 Z^{-1} + 0.939062505817492 Z^{-2}$

**Table (2):** Center frequency of contiguous digital BPF banks

Filter	Frequency (MHz)	Filter	Frequency (MHz)
BPF01	03.3	BPF17	12.9
BPF02	03.9	BPF18	13.5
BPF03	04.5	BPF19	14.1
BPF04	05.1	BPF20	14.7
BPF05	05.7	BPF21	15.3
BPF06	06.3	BPF22	15.9
BPF07	06.9	BPF23	16.5
BPF08	07.5	BPF24	17.1
BPF09	08.1	BPF25	17.7
BPF10	08.7	BPF26	18.3
BPF11	09.3	BPF27	18.9
BPF12	09.9	BPF28	19.5
BPF13	10.5	BPF29	20.1
BPF14	11.1	BPF30	20.7
BPF15	11.7	BPF31	21.3
BPF16	12.3		

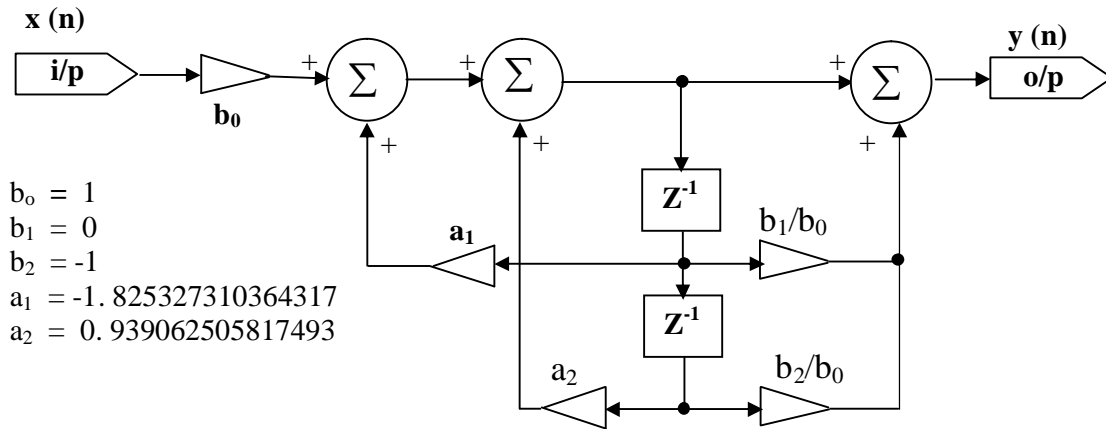

**Fig. (2):** IIR Second Order Butterworth BPF Realization.

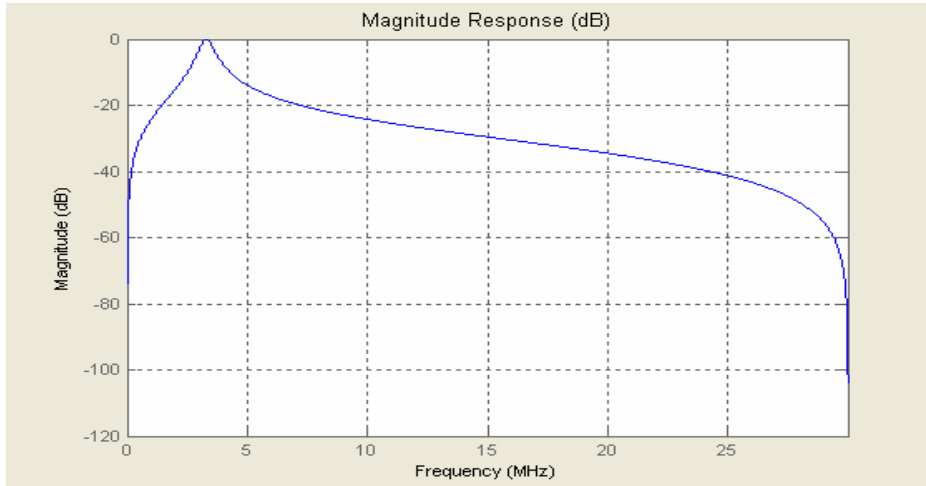

**Fig. (3):** The magnitude response of IIR second order .

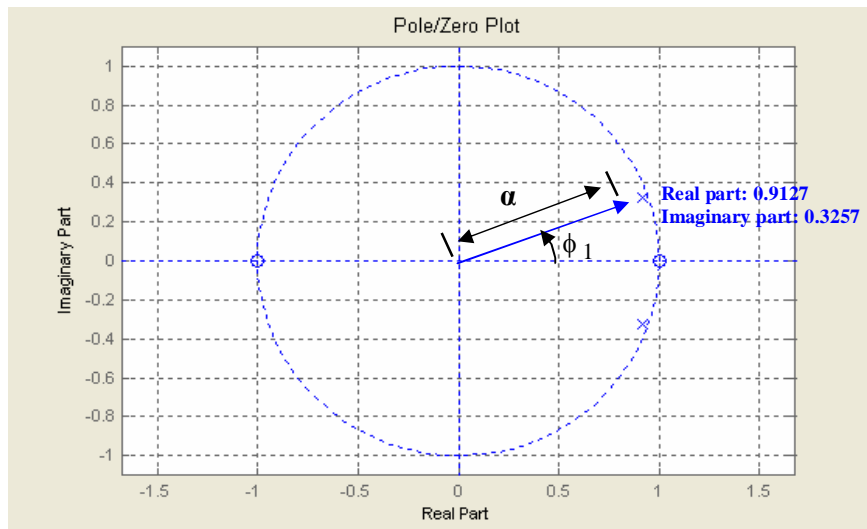

**Fig.(4):** The pole zero configuration of IIR second order BPF01 .

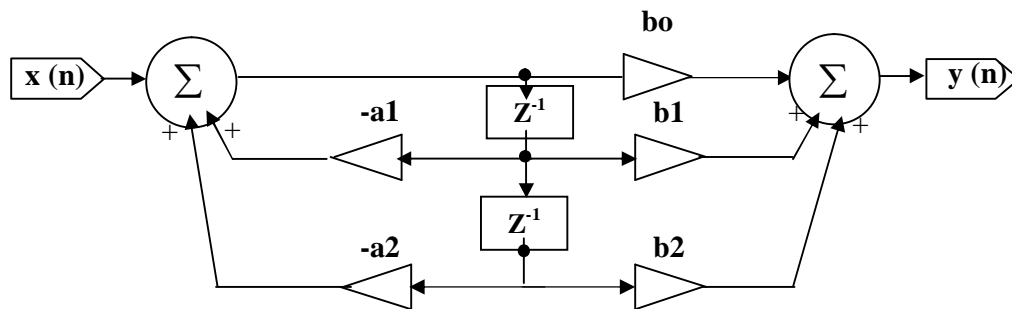

**Fig.(5):** The direct form II realization of the biquadratic section.  
 $(H(z) = (b_0 + b_1.z^{-1} + b_2.z^{-2}) / (1 + a_1.z^{-1} + a_2.z^{-2}))$ .

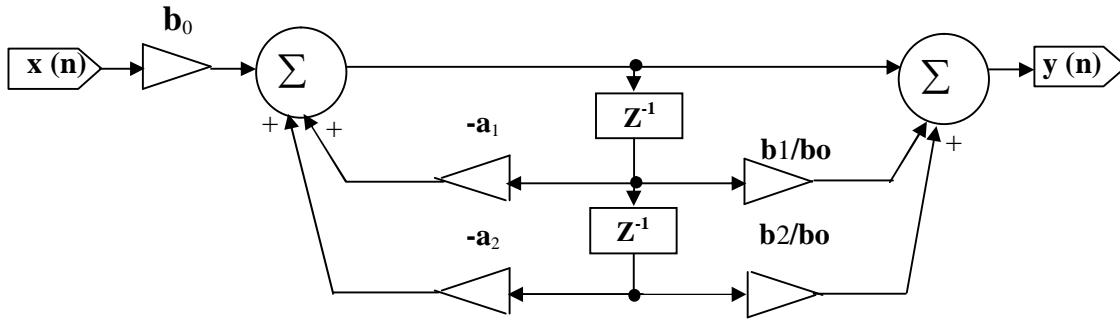

**Fig. (6):** An alternative realization of the biquadratic section.  
 $(H(z) = b_0 (1 + (b_1/b_0) z^{-1} + (b_2/b_0) z^{-2}) / (1 + a_1 z^{-1} + a_2 z^{-2}))$ .

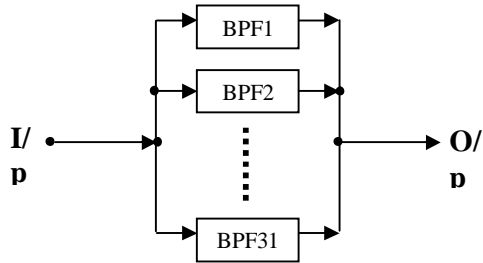

**Fig.(7):** Parallel IIR Second Order Butterworth BPF.

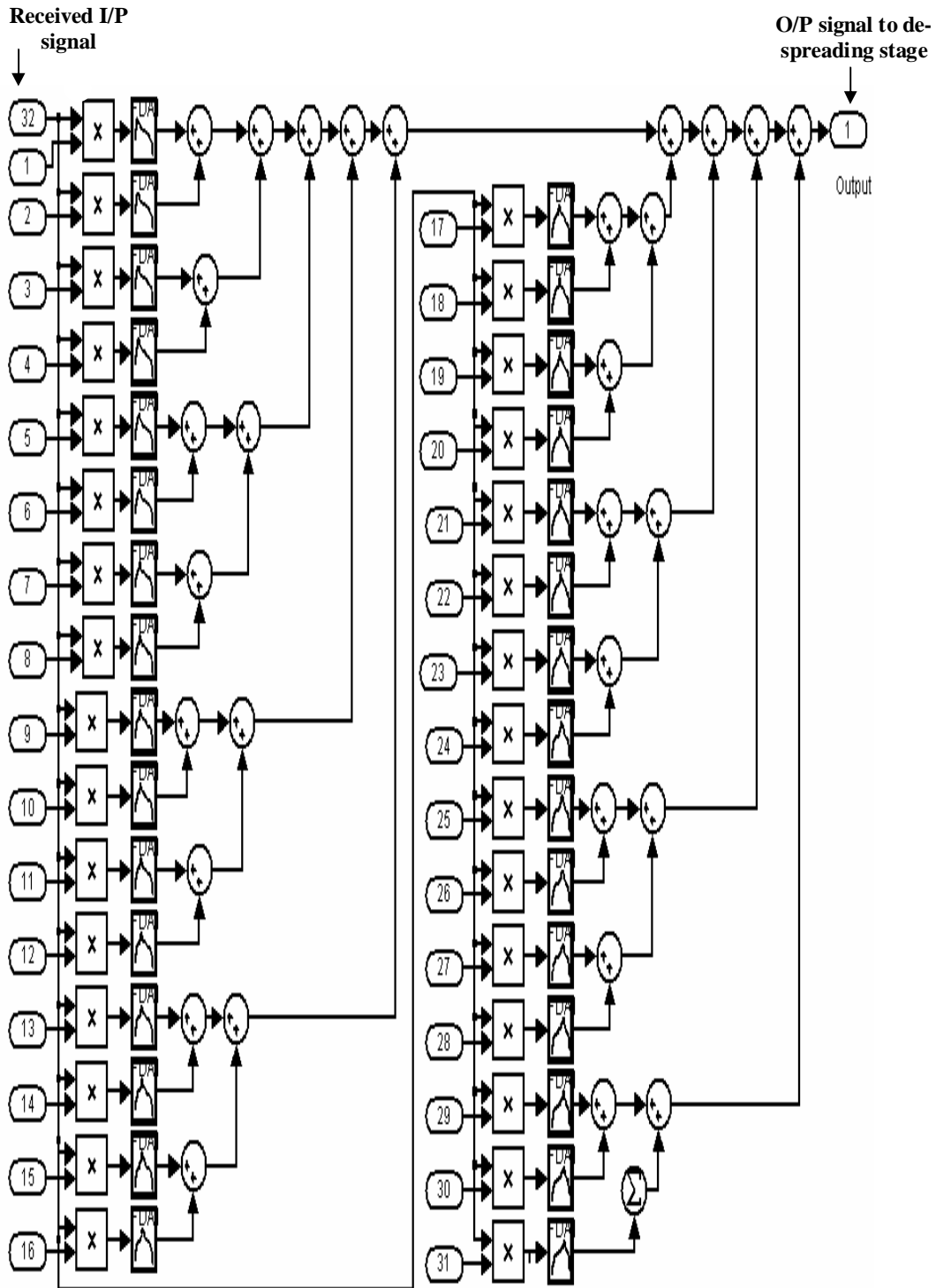

**Fig.(8):** Design and simulation of parallel IIR second order Butterworth BPF banks for FH/SS. [(1,2, ..... , 31) is the digital I/P used for controlling of BPFs]

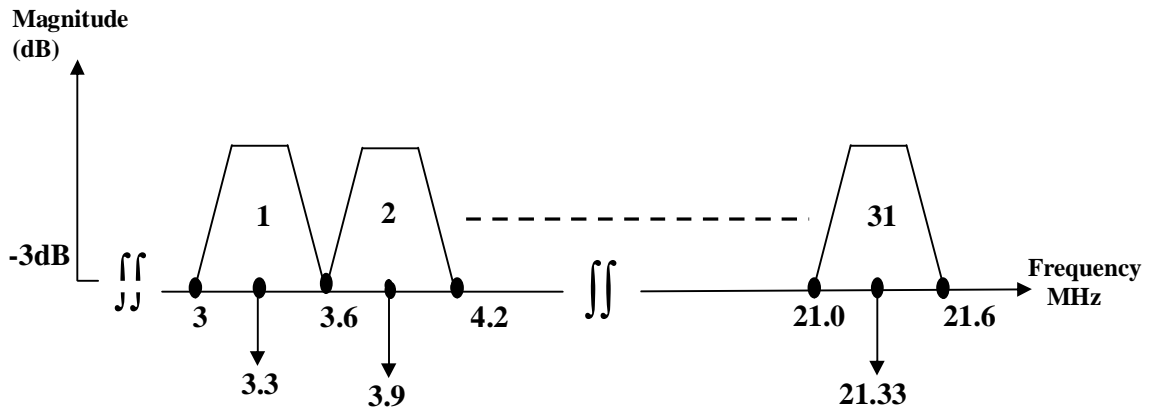

Fig.(9): The distribution of the frequencies over the band 3-31.6 MHz .

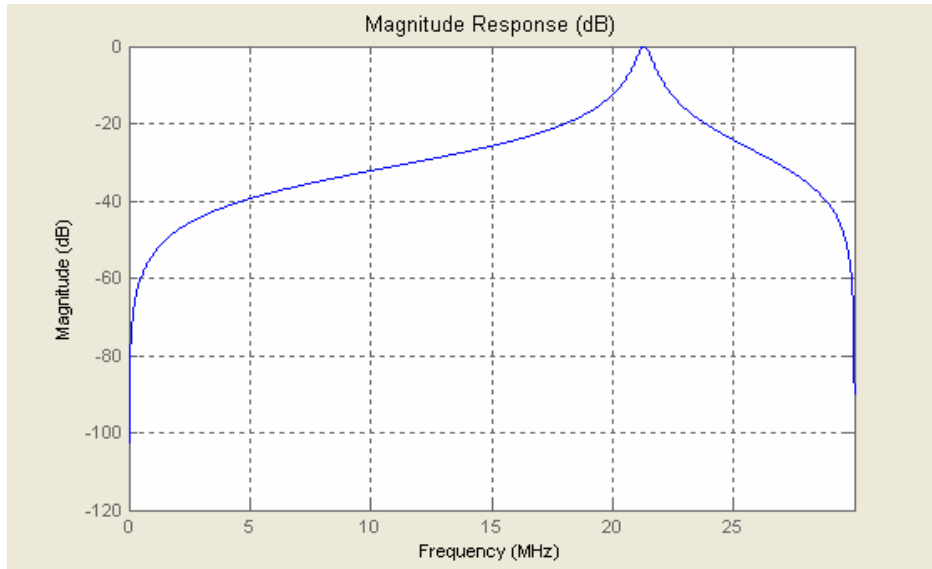
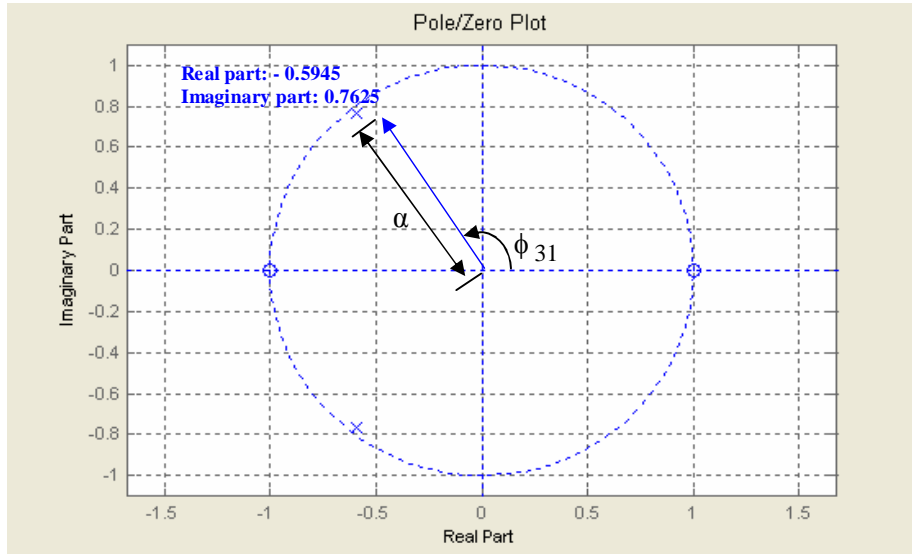
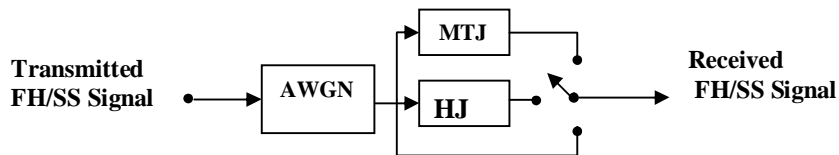

Fig.(10): The magnitude response of IIR second order BPF31.



**Fig. (11):** The pole zero configuration of IIR second order BPF31.



**Fig. (12):** Transmission channel.

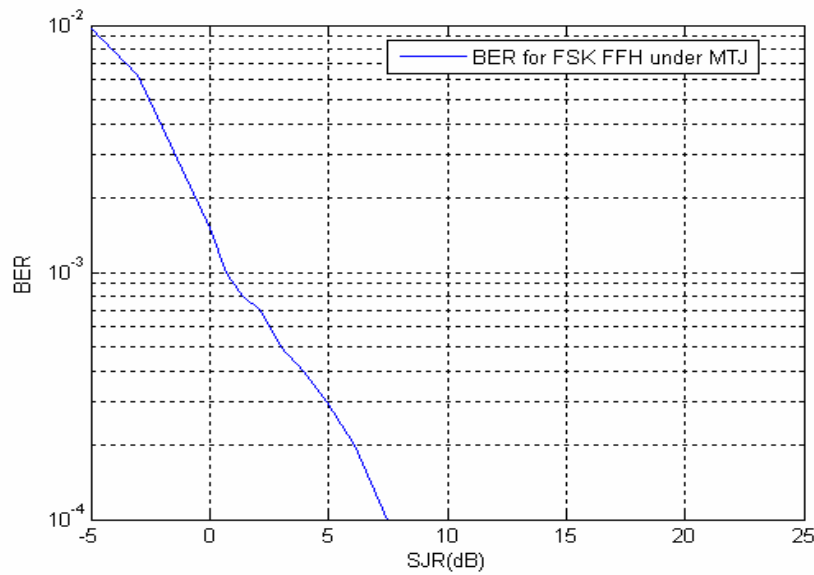

**Fig. (13):** Block Diagram of ASK FH /SS Transceiver System.



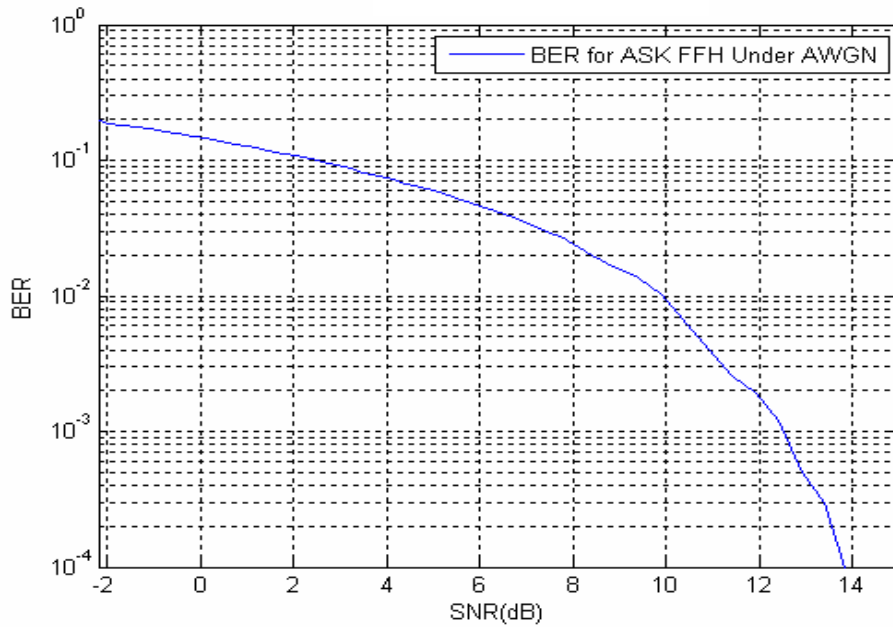

Fig. (14): BER versus SNR (dB) under AWGN.

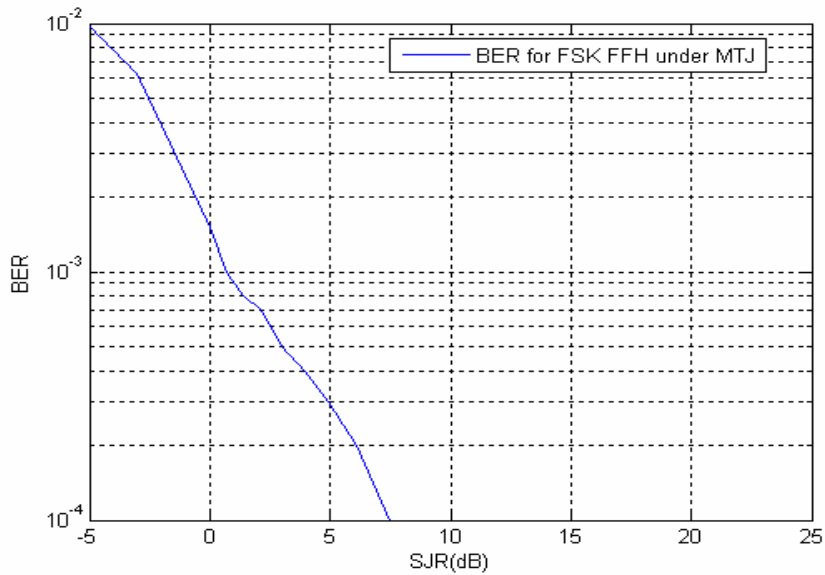

Fig.(15): BER versus SJR (dB) under MTJ.

## تصميم ومحاكاة منظومة الطيف المنتشر بالتضمين السعوي الرقمي ذات القافز الترددي 31 قناة باستخدام مرشحات رقمية غير متداخلة

د.علي عباس علي

أستاذ

قسم الهندسة الكهربائية والالكترونية

جامعة الاسراء\_جامعة الاردن

د.خالد عواد حمود

مدرس

كلية الهندسة\_جامعة ديالى

### الخلاصة

في هذا البحث تم اقتراح تصميم ومحاكاة منظومة الطيف المنتشر بالتضمين السعوي الرقمي ذات قافز ترددي 31 قناة باستخدام مرشحات رقمية متسلسلة. التصميم المقترح نفذ باستخدام نظام المحاكاة. توجد عدة تقنيات للترزامن التي يمكن استخدامها في منظومات الطيف المنتشر ذات القافز الترددي اغلب هذه التقنيات تتطلب بحث معقد لذلك فأن بنائها معقد ومكلف جداً. في هذا البحث تم تصميم وتنفيذ محاكاة مرشحات رقمية متوازية لمرور حزم ترددات محددة ثم استخدام هذه المرشحات المصممة أعلاه كطريقة جديدة وبسيطة وكفوءة للترزامن بين الإرسال والاستلام لمنظومة الطيف المنتشر بالتضمين السعوي ذات القافز الترددي للقفز في 31 قناة. النظام المقترح يمكن استخدامه لإرسال واستلام معلومات رقمية بمعدل بيانات مرسله 160000 رقم ثنائي / ثانية ومساوية لمعدل قفز 160000 قفزة / ثانية . البيانات المرسله نشرت على حزمة التردد العالي (HF) ويعرض نطاق (3- 18.6MHz) (21.6MHz) تم تصميم ومحاكاة نموذجين للتشويش. هما التشويش متعدد النغمات والتشويش القافز. النظام المقترح أعلاه تم اختباره بوجود الضوضاء (AWGN) وكلا النوعين من التشويش. النتائج المستحصلة برهنت بأن النظام أعلاه قد اجتاز هذه الاختبارات بنجاح.