

## **Effect of Curvature Ratio on The Heat Transfer and Pressure Drop in Coiled Tube**

**Harith Noori Mohammed**

Department of Chemical Engineering, Collage of Engineering, University of Tikrit  
(Received:21/2/2009; Accepted:17/8/2009)

**ABSTRACT** - An experimental study has been conducted on steady-state natural convection heat transfer from helical coil tubes. Water was used as a bath liquid without any mixing and air was used as a coolant fluid. A straight copper tube of 13 mm ID, 14 mm OD and 3 m length were bend to fabricate the helical coil. Two coils are used in this experiment has a curvature ratio of 0.1101 and 0.0942. The data were correlated using tube diameter as the characteristic length. The results show that the overall heat transfer coefficient and pressure drop are increased when the flow rate of coolant and curvature ratio increase. Two correlations are presented to calculate the average Nusselt number inside and outside of coil.

**Keywords:** Coil, Curvature, Heat transfer, Pressure drop.

---

### *Nomenclature*

- D helix coil diameter, m  
d tube diameter, m  
T temperature, °C  
Q heat transfer rate, W  
m mass flow rate, kg/s  
Cp specific heat, kJ/kg °C  
U overall heat transfer coefficient, W/m<sup>2</sup> °C  
A surface area, m<sup>2</sup>  
 $\Delta T_{lm}$  log mean temperature, °C  
h heat transfer coefficient, W/m<sup>2</sup> °C  
k thermal conductivity, W/m °C  
L coil length, m

- Nu Nusselt number,  $h_i d_i/k$   
Re Reynolds number,  $\rho d_i u/\mu$   
Ra Rayleigh number,  $g \beta (T_{aw} - T_\infty) d_o^3 \nu^{-1} \alpha^{-1}$   
Gr Grashof number,  $g \beta (T_{aw} - T_\infty) d_o^3 \nu^{-2}$

***Greek Symbols***

- $\nu$  kinematic viscosity,  $m^2 s^{-1}$   
 $\alpha$  thermal diffusivity,  $m^2 s^{-1}$   
 $\beta$  coefficient for thermal expansion,  $K^{-1}$   
 $\rho$  density,  $kg/m^3$   
 $\mu$  viscosity,  $kg/m.s$   
 $\infty$  ambient medium

***Subscripts***

- i inner  
b bulk  
o outer  
aw average wall

**1- INTRODUCTION**

Coiled tubes are used in many engineering applications, such as heating, refrigeration, and HVAC systems. They are used also in steam generator and condenser design in power plant because of their large surface area per unit volume. In the present study, two coils of (0.1101 and 0.0942) curvature ratios were used to predict the effect of these ratios on the nature of overall heat transfer coefficient and pressure drop.

Coronel, et al<sup>(1)</sup> reported an experimental study to determination of convective heat transfer coefficient in both helical and straight tubular heat exchangers under turbulent flow conditions. Their experiments were conducted in helical heat exchangers, with coils of two different curvature ratios ( $d/D = 0.114$  and  $0.078$ ), and in the straight tubular heat exchanges at various flow rates ( $1.89 \times 10^{-4} - 6.31 \times 10^{-4} m^3/s$ ) and for different end-point temperatures ( $92 - 149$  °C). The results showed that the overall heat transfer coefficient in the heat exchanger of helical tube is much higher than that in straight tubular heat exchangers. In addition the overall heat transfer coefficient was found to be larger in the coil of larger

curvature ratio (  $d/D = 0.114$  ) than in the coil of smaller curvature ratio (  $d/D = 0.078$  ). A correlation to compute the inside convective heat transfer coefficient as a function of Reynolds number, Prandtl number and  $d/D$  was developed. Paisarn and Jamnean<sup>(2)</sup> simulate the turbulent flow and heat transfer developments in the horizontal spirally coiled tubes with three different curvature ratios of 0.02, 0.04, 0.05 under constant wall temperature. The spirally coiled tube is fabricated by bending a 8.00 mm diameter straight copper tube into a spiral-coil of five turns. Cold water entering the innermost turn flows along the spiral tube and flows outermost turn. They concluded that the centrifugal force has significant effect on the enhancements of heat transfer and pressure drop. In addition, due to this force, the heat transfer and pressure drop obtained from the spirally coiled tube are higher than those from the straight tube. Mohamed<sup>(3)</sup> reported an experimental study on steady-state natural convection heat transfer from vertical helical coil tubes in heat transfer oil of a Prandtl number range of 250-400. Fifteen coils are used in this experiment. These coils are classified into five groups; each group has a specified coil diameter-to-tube diameter ratio for two, five, and ten turns. The helix coil to tube diameter ratio is 30, 20.83, 17.5, 13.33, and 10. The results show that the average heat transfer coefficient increases as the coil number of turns decrease for a fixed diameter ratio, three overall empirical correlation are developed: for oil with  $250 \leq Pr \leq 400$ , the correlation between the Nusselt and Rayleigh numbers is:

$$Nu_L = 0.619 Ra_L^{0.3}, \quad 4.37 \times 10^{10} \leq Ra_L \leq 5.5 \times 10^{14}, \quad 10 \leq \frac{D}{d_o} \leq 30 \dots \dots (1)$$

for oil data and water, the correlation between the Nusselt and Grashof numbers using the Prandtl number as a parameter was reported as:

$$Nu_L = 0.555 Gr_L^{0.301} Pr^{0.314}, \quad 1 \times 10^8 \leq Gr_L \leq 5 \times 10^{14}, \quad 4.4 \leq Pr \leq 345 \dots (2)$$

an alternative correlation of oil and water using Nusselt number as a function of Rayleigh number only was reported as:

$$Nu_L = 0.714 Ra_L^{0.294}, \quad 4.35 \times 10^{10} \leq Ra_L \leq 8 \times 10^{14}, \quad 4.4 \leq Pr \leq 345 \dots (3)$$

Aravind et al.<sup>(4)</sup> reported an experimental study of natural convective heat transfer from helical coiled tube immersed in a cylindrical vessel as a bath without any mixing of the liquid. Water, soap solutions and carboxy methyl cellulose (CMC) solutions are used as bath liquids and cooling water was entered through one end of the coil. They concluded that the overall heat transfer coefficients for soap and CMC solutions have been found to be below that of water and in case of water in the bath, a peak overall heat transfer coefficient is noted.

Ali<sup>(5)</sup> reported an experimental investigation of laminar-and transition-free convection heat transfer from the outer surface of helical pipes with a finite pitch oriented vertically in a

57% glycerol-water solution by mass. His experiments were carried out for three coil diameter to tube diameter ratio,  $D/d_o$ , and for five and ten coil turns. The results show that the heat transfer coefficient is enhanced either by reducing the diameter ratio or the number of coil turns. The overall correlations covering all the data are reported as:

$$Nu_L = 1.535 \times 10^{-5} Ra_L^{0.671} \left( \frac{D}{d_o} \right)^{-0.702}, \quad 7 \times 10^{12} \leq Ra_L \leq 8 \times 10^{14} \dots\dots (4)$$

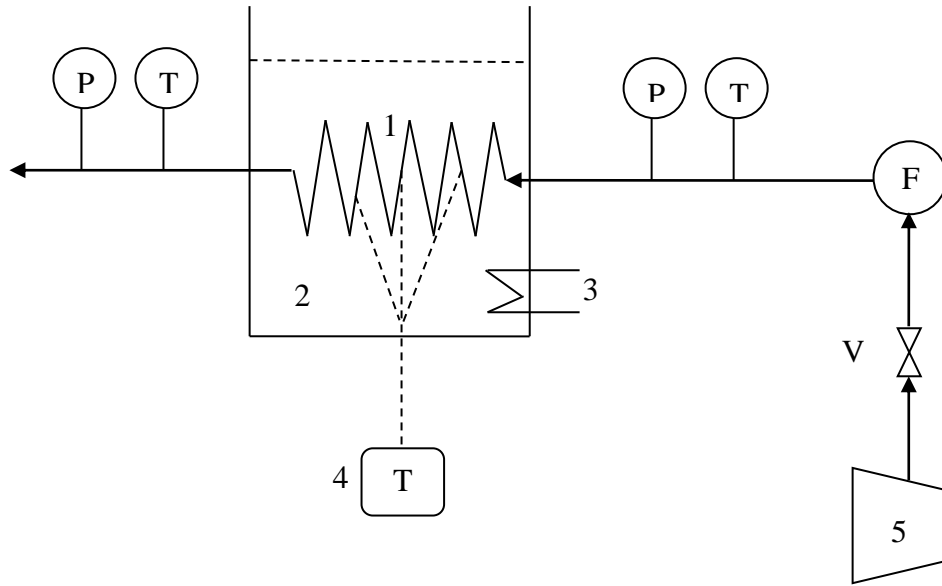
$$Nu_L = 1.535 \times 10^{-5} Ra_L^{0.671} \left( \frac{D}{d_o} \right)^{-0.702}, \quad 7 \times 10^{12} \leq Ra_L \leq 8 \times 10^{14} \dots\dots (5)$$

Choi et al.<sup>(6)</sup> reported an numerical analysis to find flow and heat characteristics for coil heat exchanger system with forced convection flow. For the analysis, three different connection types of inlet and outlet ports are selected with Reynolds number varying in the range of 2,000 and 200,000. among these different connections, middle location case is found to yield better characteristics than others.

## **2- EXPERIMENTAL SETUP AND PROCEDURE**

The coils of two different curvature ratios ( $d_i/D = 0.1101$  and  $0.0942$ ) used in these experiments are fabricated by bending a copper pipe of 13mm ID and 3m long. The coil length was measured before forming it, and the outer diameter ( $D$ ) of the coil is measured using a vernier caliper. The test coil is carried out in a different ambient temperatures bath ( $30 \times 50 \times 20 \text{ cm}^3$ ), which serves as a heating medium. This ambient bath has a water heat transfer. The copper-constantan thermocouples were attached and digital temperature indicator of two digits accuracy was used to measure wall temperature of coil at five different locations and then evaluated average wall temperature ( $T_{aw}$ ). The distances between thermocouples locations are 50 cm.

Air was pumped in the tube coil as a coolant with different volumetric flow rates ( $2-5 \text{ m}^3/\text{hr}$ ) were measured by flow meter having a range of ( $1.5 - 16 \text{ m}^3/\text{hr}$ ). The bath temperature, inlet and outlet temperatures were measured by mercury thermometer having a range of ( $0-200 \text{ }^\circ\text{C}$ ). The pressure drop through the coil was measured in ( $\text{mm H}_2\text{O}$ ) using U-tube manometer. The schematic diagram of experimental set-up is shown in Figure 1.



**Fig.(1):-** Flow diagram of the experimental set-up

- |                                  |                        |
|----------------------------------|------------------------|
| 1- coil                          | P- pressure manometer  |
| 2- water bath                    | T- mercury thermometer |
| 3- electrical heater             | F- flowmeter           |
| 4- digital temperature indicator | V- gate valve          |
| 5- compressor                    |                        |

In each test the bath was filled with water submerging the coil completely. Heating was done by immersion coil and simultaneously cooling air was entered through one end of the coil. At steady state conditions, bath temperature and air temperature (both at inlet and outlet sections) were measured. The wall temperatures were noted also. The experiments were conducted for seven different flow rates.

### 3- ANALYSIS OF EXPERIMENT

The physical properties of air flowing inside the tube coil test section are assumed constant along the coil length and evaluated at the average bulk temperature for each run. The overall heat transfer rate through the coil can be evaluated from:

$$Q = m \cdot C_p (T_{b2} - T_{b1}) \dots\dots\dots(6)$$

Where Q is the overall heat transfer rate through the coil, m' is the mass flow rate of air,  $T_{b1}$  is the coil inlet temperature,  $T_{b2}$  is the coil outlet temperature, and  $C_p$  is the air specific heat. Having obtained a value for the heat transfer rate Q, is calculated from:

$$U_o = \frac{Q}{A_o \Delta T_{lm}} \quad , \quad \Delta T_{lm} = \frac{T_{b2} - T_{b1}}{\ln \left[ \frac{T_{\infty} - T_{b1}}{T_{\infty} - T_{b2}} \right]} \dots\dots\dots(7)$$

And  $U_o$  is defined as:

$$U_o = \left[ \frac{1}{\frac{A_o}{A_i h_i} + \frac{A_o \ln(d_o/d_i)}{2\pi k L} + \frac{1}{h_o}} \right] \dots\dots\dots(8)$$

Where  $h_i$  is the coil inside heat transfer coefficient,  $h_o$  is the outer heat transfer coefficient. Once  $U_o$  is calculated from Eq.(7),  $h_o$  is evaluated from the following equation:

$$h_o = \frac{Q}{A_o (T_\infty - T_{aw})} \dots\dots\dots(9)$$

Where  $T_\infty$  is the ambient temperature,  $T_{aw}$  is the average wall temperature. The inside heat transfer coefficient  $h_i$  can be calculated from Eq.(8). The physical properties of air are evaluated from Holman<sup>(7)</sup>.

The average Nusselt and Rayleigh numbers were generated using the tube diameter as a characteristic dimension to determine the range of Rayleigh and Nusselt numbers and its relation to the region of natural convection.

#### **4- RESULTS AND DISCUSSION**

The characteristic of wall temperature variation is shown in figures 1-a and 1-b. It is noticed that the wall temperature of coil is almost constant due to the thermal properties of air (specific heat and thermal conductivity). The behavior of the overall heat transfer coefficient at the various ambient temperatures can be seen in figure 2. As expected, the overall heat transfer coefficient is directly proportional to the mass flow rate of the fluid inside the coil at a constant bath temperature.

The curvature ratio has significant effect on the overall heat transfer coefficient which can be seen in figure 3. It illustrate that the curvature ratio ( $d_i/D = 0.1101$ ) gives a higher values of overall heat transfer coefficient than the ratio ( $d_i/D = 0.0942$ ), i.e. the overall heat transfer coefficient was increase when the curvature ratio of coil increase. Figure 4 show the variation of the average inner Nusselt number calculated from the present experiment with Reynolds number. It illustrates that when the Reynolds number increase leads an increase the Nusselt number. This is because the Nusselt number depends directly on the heat removal capacity of the cold air. In addition the curvature ratio ( $d_i/D = 0.1101$ ) gives a higher values of Nusselt number than the ratio ( $d_i/D = 0.0942$ ) this is because the centrifugal force increase when the

curvature ratio increase. The correlation covering the experimental data point inside the tube coil with correlation coefficient R=99.87% is :

$$Nu_{di} = 0.649 Re^{1.99} Pr^{34.73} \left(\frac{d_i}{D}\right)^{1.59} \dots\dots\dots(10)$$

Figure 5 show similar results of the average Nusselt number vs. Reynolds number for two coil curvature ratios.

Increasing the volume flow rate will increase the inside heat transfer coefficient and the amount of heat dissipated to the ambient medium of water. However, the outside heat transfer coefficient is almost independent of the flow rate. This behavior of the outer heat transfer coefficient can be seen in a nondimensional form of  $Nu_{do}$  and  $Ra_{do}$  in Figure 6 for two coils with Rayleigh number range of  $7 \times 10^4 - 2.5 \times 10^5$ .

It can be seen from this figure that the Nusselt number increases as the Rayleigh number increases. The correlation covering the experimental data piont outside the coil with correlation coefficient R=96.14% is:

$$Nu_{do} = 0.1466 Ra^{0.7622} \left(\frac{d_i}{D}\right)^{2.847} \dots\dots\dots(11)$$

Figure 7 show similar results of the average Nusselt number vs. Rayleigh number for two coil curvature ratios.

The characteristic of pressure drop for the coil is shown in figure 8. It represent that increasing in the flow rate of air leads to increase the pressure drop and a highest curvature ratio has been the greatest values of pressure drop.

## **5- CONCLUSIONS**

Experimental studies on steady-state natural convection heat transfer in helical coil in water bath were performed. The following conclusions could be drawn:

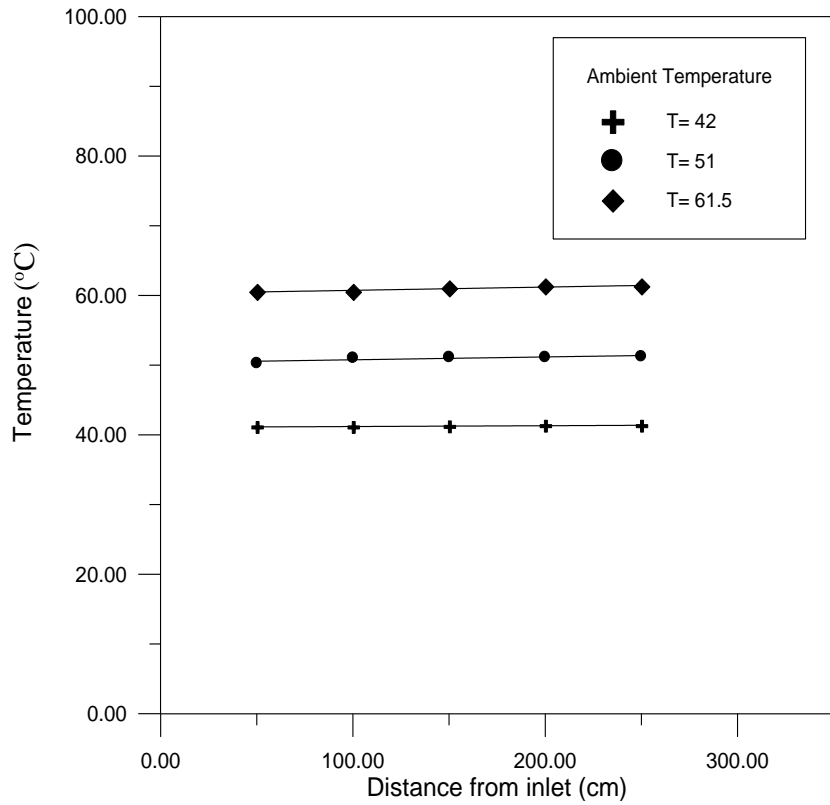
- 1- The overall heat transfer coefficient and Nusselt number are increases as the flow rate of coolant increase.
- 2- The curvature ratio  $d_i/D = 0.1101$  gives a higher values of overall heat transfer coefficient than the ratio  $d_i/D = 0.0942$ , in addition when the curvature ratio of coil increase the Nusselt number values increase also.
- 3- Increasing in the curvature ratio and flow rate leads to increasing in the pressure drop in helical coil.

- 4- Two empirical correlations are developed for inner Nusselt number as a function of Reynolds number, Prandtl number and curvature ratio is given by Eq. (10), and outer Nusselt number as a function of Rayleigh number and curvature ratio is reported by Eq. (11).

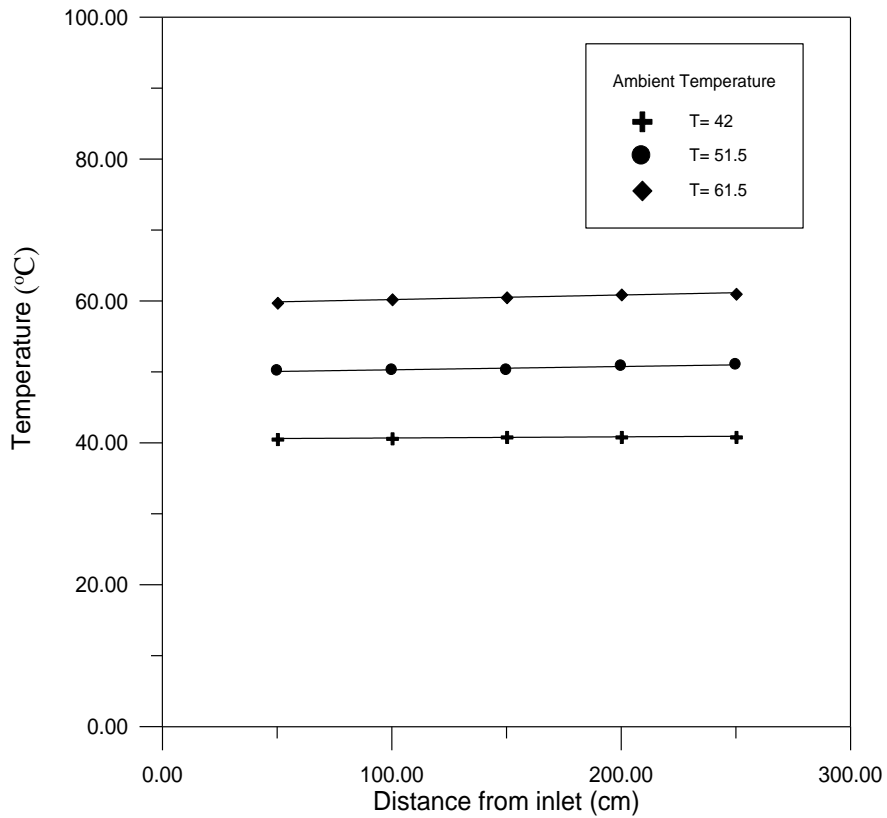
## **REFERENCES**

1. Coronel, P. and Sandeep, K. P., "Heat Transfer Coefficient in Helical Heat Exchangers under Turbulent Flow Condition", *International Journal of Food Engineering*, vol. 4: Iss. 1, Article 4, (2008).
2. Paisarn N. and Jamnean S., "Effect of Curvature Ratio on the Heat Transfer and Flow Developments in the Horizontal Spirally Coiled Tubes", *Int. J. Heat and Mass Transfer*, vol. 50, pp. 444-451, (2007).
3. Mohamed E. Ali, "Natural Convection Heat Transfer from Vertical Helical Coils in Oil", *Heat Transfer Engineering*, vol. 27, no. 3, (2006).
4. G. S. Aravid, Y. Arun, R. S. Sunder and S. Subrahmaniyam, "Natural Convection Heat Transfer in Helical Coiled Heat Exchanger", *IE (I) Journal-CH*, vol. 84, (2003).
5. Ali, M. E., "Free Convection Heat Transfer from the Outer Surface of Vertically Oriented Helical Coils in Glycerol-Water Solution", *Heat and Mass Transfer*, vol. 40, no. 8, pp. 615-620, (2004).
6. H.K. Choi, G.J. Yoo, S.S. Kim, and Y.S. Choi, *Numerical Analysis of Heat Transfer Characteristics for Coiled Heat Exchanger*, ACTA Press, (2007).
7. Holman, J. P. *Heat Transfer*, 5th edition, McGraw-Hill, New York, (1981).

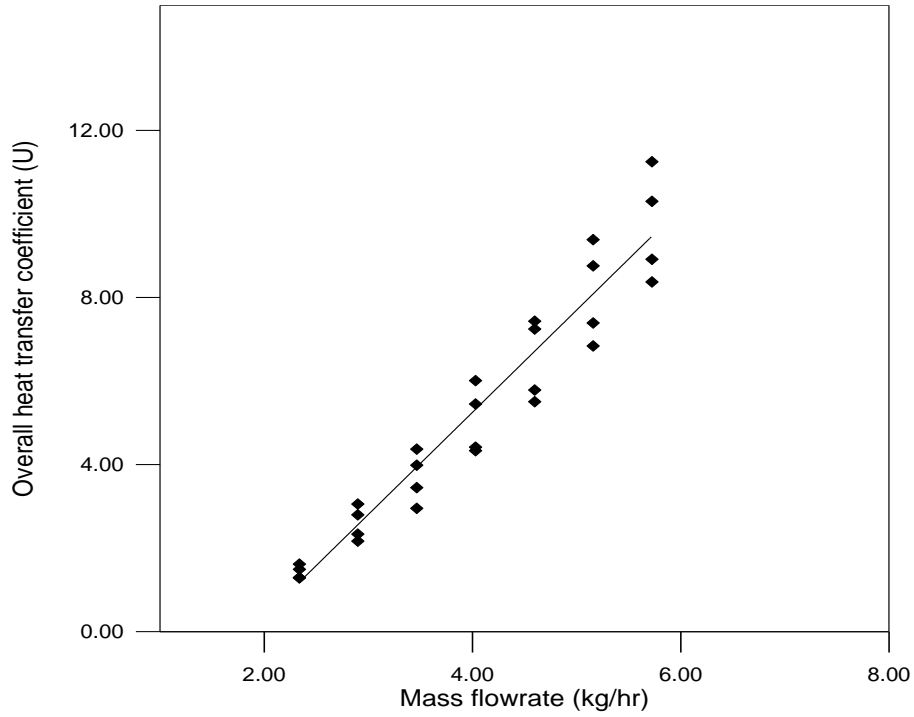




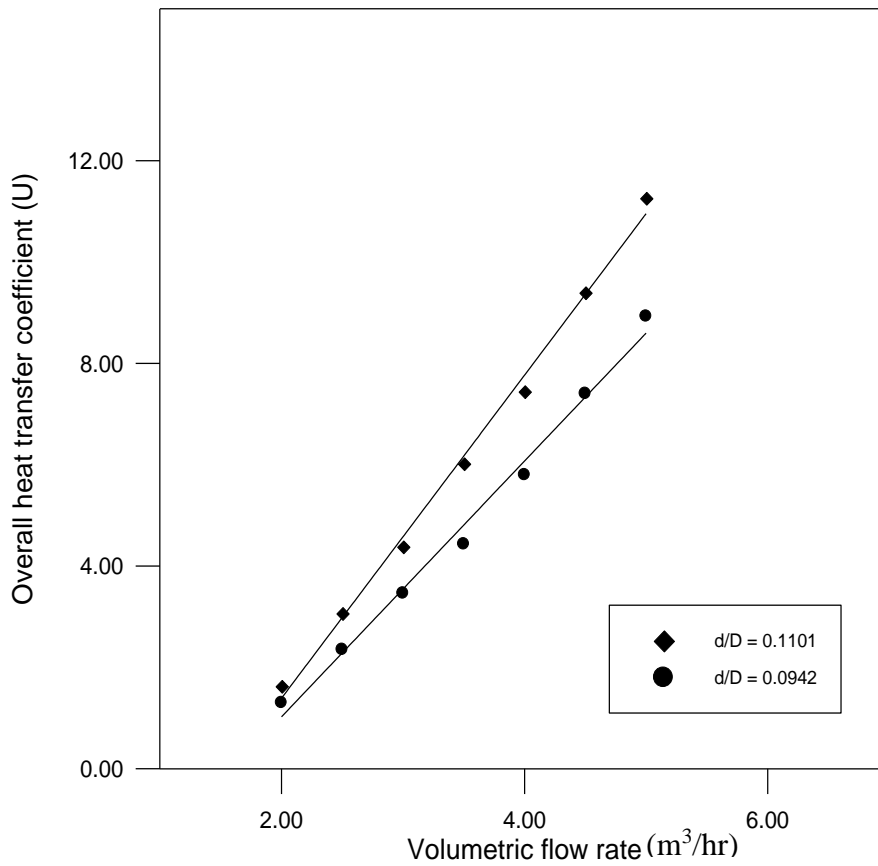
**Fig.(1) a:-** The characteristic of wall temperature variation for coil of  $d_i/D = 0.1101$



**Fig.(1) b:-** The characteristic of wall temperature variation for coil of  $d_i/D = 0.0942$



**Fig.(2):-** The behavior of the overall heat transfer coefficient for tow coils.



**Fig.(3):-** The effect of the curvature ratio of coil on the overall heat transfer coefficient.

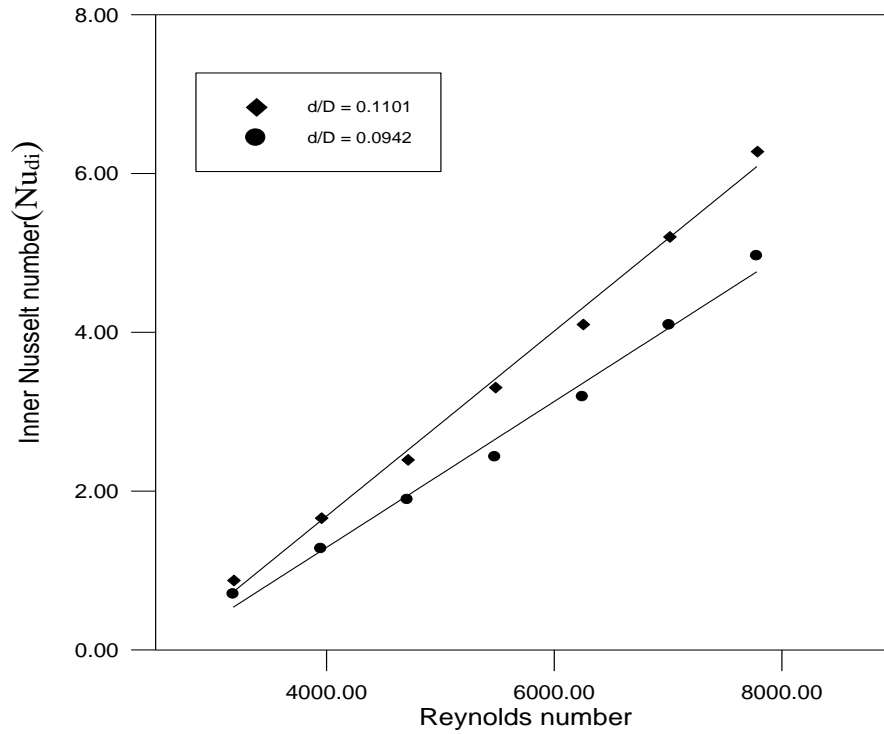


Fig.(4):- The variation of inner Nusselt number with Reynolds number for two coils.

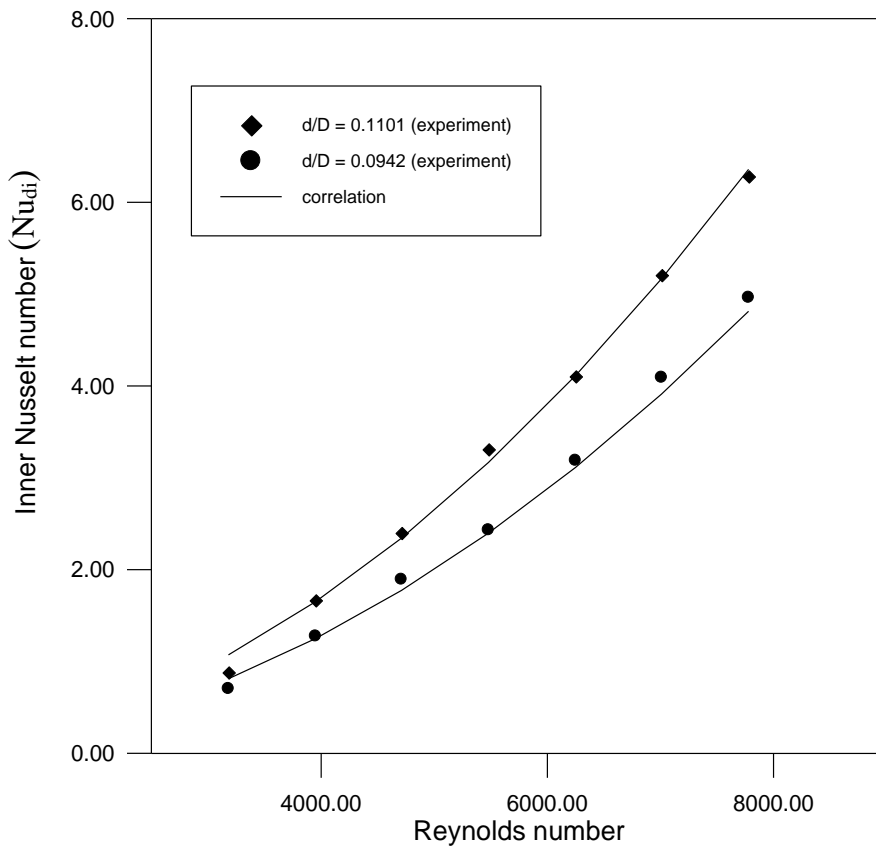


Fig.(5):- Experimental and correlation inner average Nusselt number for two test coils

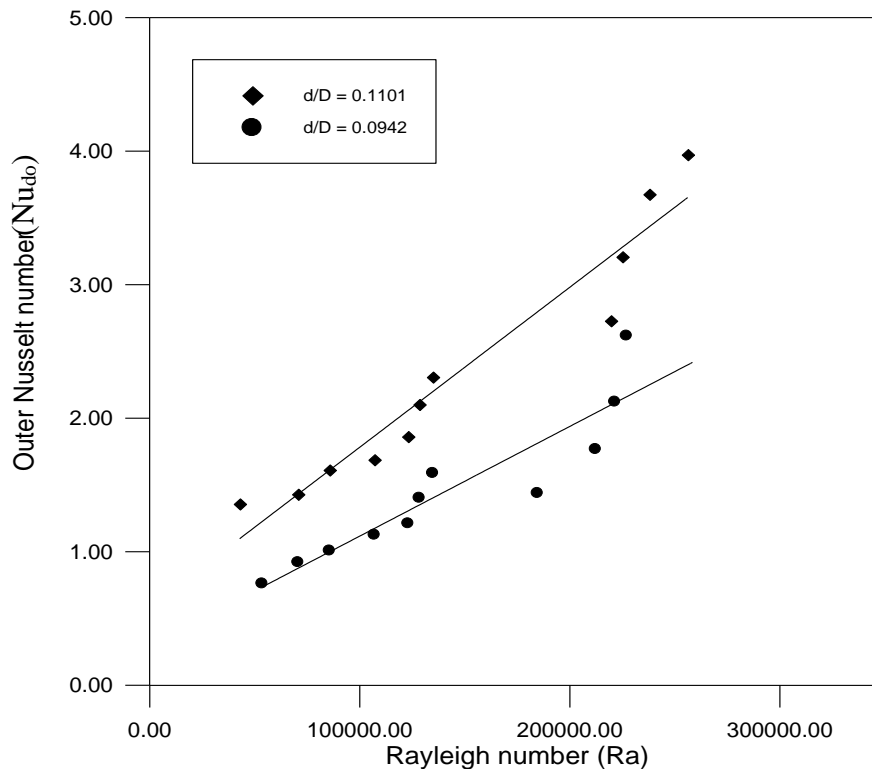


Fig.(6):- The behavior of Nusselt and Rayleigh numbers for two coils

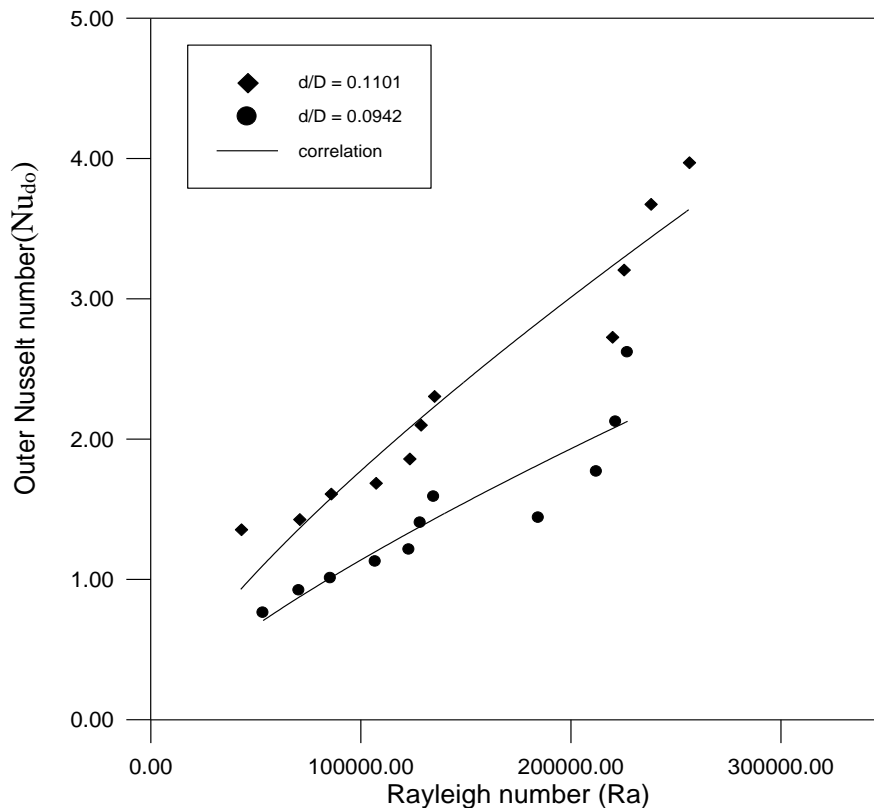
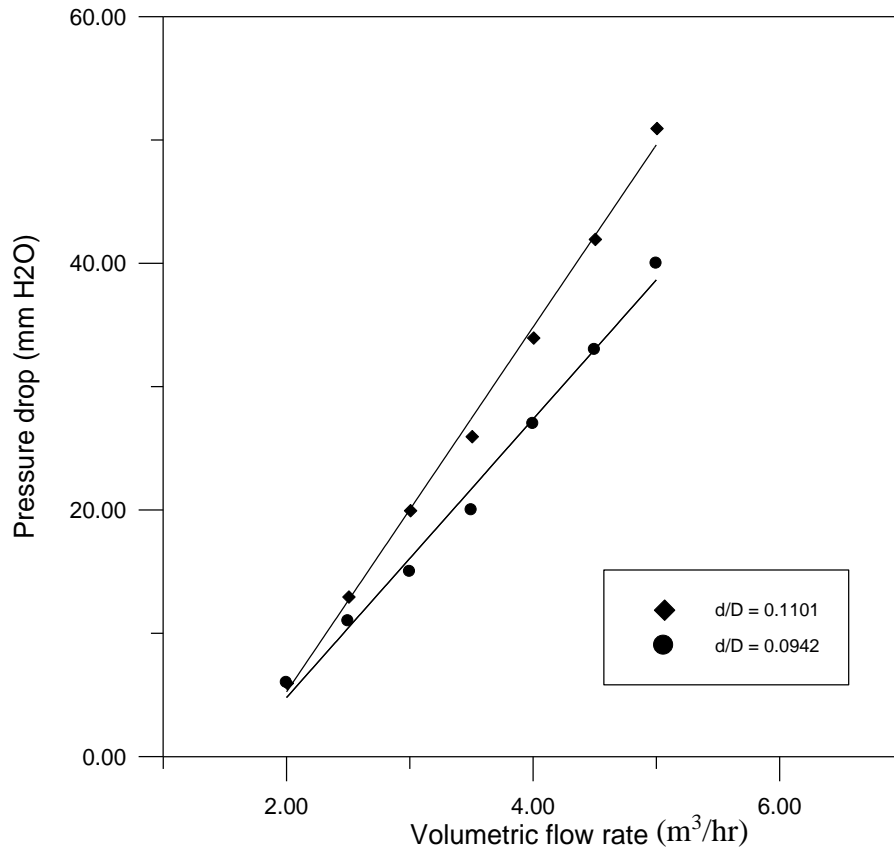


Fig.(7):- Experimental and correlation average outer Nusselt number for two test coils



**Fig.(8):-** Effect of coil curvature ratio on pressure drop

## تأثير نسبة التقوس على انتقال الحرارة وفرق الضغط في الأنابيب الحلزونية

حارث نوري محمد

مدرس مساعد

كلية الهندسة . جامعة تكريت

### الخلاصة

إن الغرض من هذا البحث هو دراسة تأثير نسبة التقوس على خصائص انتقال الحرارة وفرق الضغط في الأنابيب الملفوفة بشكل حلزوني حيث تمت دراسة هذا التأثير عملياً. نظام انتقال الحرارة المستخدم في التجربة هو نظام الحمل الحراري الطبيعي عند الحالة المستقرة. تم وضع الحلزون في حمام مائي عند درجات حرارة مختلفة وقد ادخل الهواء (مائع التبريد) داخل الحلزون. تم تشكيل الحلزون وذلك بثني أنبوب من النحاس قطره الداخلي ١٣ ملم و قطره الخارجي ١٤ ملم ويبلغ طوله ٣ متر. أجريت التجارب على حلزونين وبنسبة تقوس (٠,١١٠١ ، ٠,٠٩٤٢). تم استخدام قطر الأنبوب الملفوف في الحسابات. بيّنت التجارب العملية إن معامل انتقال الحرارة الكلي وفرق الضغط يزداد بزيادة معدل جريان المائع داخل الحلزون وكذلك بزيادة نسبة التقوس للأنابيب الحلزونية. تم إيجاد معادلي تصحيح من التجارب العملية لحساب عدد نسلت (Nusselt number) في داخل أنبوب الحلزون (معادلة ١٠) وكذلك خارج الحلزون (معادلة ١١).  
الكلمات الدالة:- ملف، نسبة التقوس، انتقال الحرارة، فرق الضغط.