

Structural Behavior of Reinforced Lightweight Concrete Slabs

Yahyia M. Hameed ^{1,*}, Murtada A. Ismael ²

¹Department of Civil Engineering, University of Diyala, 32001 Diyala, Iraq

²Department of High way and Airport Engineering, University of Diyala, 32001 Diyala, Iraq

ARTICLE INFO

Article history:

Received March 22, 2022

Accepted May 30, 2022

Keywords:

Structural

Reinforced

Lightweight

Concrete slabs

ABSTRACT

This paper presents an exploration of choosing the optimum density for concrete that achieves the best structural performance for two-way slabs made of concrete with fine aggregate in different proportions less than the ratio used in ordinary concrete to produce different densities, by taking advantage of the idea of fine aggregate concrete which considers as light-weight concrete to achieve lighter concrete with higher structural endurance. The experimental program includes constructing and testing five slabs, four of them made of concrete with different fine aggregate ratios 75%, 50%, 25%, and 0% to get different densities (2207, 1792, 1536, 1310 kg/m³) as well as another slab made of normal concrete used as a reference slab with a density of 2414 kg/m³. The outcomes reveal that decreasing the density of the slab from 2414 kg/m³ to 1310 kg/m³ by reduction fine aggregate in concrete from 100% to 0% respectively has more effect on the first crack load than that on the ultimate load of two-way slabs as the first crack load decreases with percentages 16.7%, 33.3%, 38.9%, and 61.1% the while the ultimate load decreases with percentages 7.3%, 21.9%, 46.3%, and 56.1%, respectively as compared to the reference (normal wight concrete slab). Also, decreasing the density of the slab made the cracks form and spread quickly and the slab failure tends towards the brittleness, and the cracks diffused and grew faster and wider.

1. Introduction

In recent years, lightweight concrete (LWC) has created a lot of interest and industry demand in a number of constructions. The oven dry density of LWC ranges from about 300 to not more than 2000 kg/m³ [1]. The methods of production can be used to classify the different types of LWC. These types are: a) aggregate lightweight concrete b) concrete with bubbled voids which is known as aerated, cellular, foamed, or gas concrete. c) concrete that doesn't contain fine aggregate which is known as no-fines concrete [2-3]. Lightweight concrete can also be classified according to the purpose of utilizing as: (a) structural lightweight concrete with a cylinder compressive strength of 17 MPa or above at 28 days and a density of 1400-1800

kg/m³, (b) The compressive strength of masonry concrete (structural / insulating lightweight concrete) ranges from 7 to 14 MPa, with a density of 500 to 800 kg/m³ (c) The compressive strength of insulating concrete is 0.7-7 kg/m³ and the density is less than 800 kg/m³ [2-3]. No-fines Concrete has several advantages over other lightweight concrete types, including lower cost due to lower cement content, good thermal conductivity, relatively low drying shrinkage (half of dense concrete), no segregation even when material is discharged from high levels, no capillary movement of water due to low hydrostatic pressure when wet (one-third of dense concrete), and better insulating properties than conventional concrete. However, since it lacks small particles, this concrete is not used as structural concrete due to its low compressive

* Corresponding author.

E-mail address: yahyamajeed@gmail.com

DOI: [10.24237/djes.2022.15212](https://doi.org/10.24237/djes.2022.15212)



strength, which results in large voids and a significant reduction in resistance [3-6]. In this work, concrete will be made with fine aggregate that has been partially reduced with various reduction ratios in order to gain some of the benefits of no fine concrete, as well as the ability to use it as a structural material. It will then be utilized to generate two-way slabs and analyze their structural behavior in order to determine its structural performance.

In the past years, a number of studies were presented that dealt with the structural behavior of fabricated lightweight concrete slabs.

Osman et al. [7] used high-strength lightweight aggregate (HSLW) concrete to make flat plate to explore punching shear attitude at an inner column. Six slabs were subjected to central load testing in this investigation. Four slabs were built using high-strength lightweight concrete with compressive strengths greater than 70 MPa and steel ratios ranging from 0.5 to 2.0%. Abdul Rasoul [8] investigated the impact of punching shear strength on the behavior of self-compacting reinforced concrete two-way slab specimens with various orifice kinds. A series of experimental tests were conducted by Youm et al. [9] to investigate the punching shear behavior of lightweight concrete slabs. Punching shear experiments were carried out on slabs containing two different types of lightweight aggregates, and the punching shear behaviors of the slabs were compared to those of a normal-weight concrete slab. Abdulah [10] investigated the flexural behavior of reinforced light weight concrete two-way slabs strengthened with (CFRP) sheets using both experimental and theoretical methods. Zaher et al. [11] investigated the punching shear behavior of self-compacting Lightweight Concrete (LWC) slabs. To reduce the concrete dry unit weight from 23.0 kN/m³ to 18.5 kN/m³, LWC was achieved by using polystyrene foam as a partial aggregate substitute. Adil and Abdulrazzaq [12] through experimental tests

carried out on five samples different in their details and the position of the concrete type layer within the slabs, more information about the flexural behavior of composite reinforced concrete slabs using two layers of concrete, the first layer being light weight concrete (LWC), and the second layer being normal weight concrete (NWC) was sought. The behavior of reinforced shear span to effective depth (a/d) was investigated by Al-Azzawi and Abdul Al-Aziza [13]. Seven reinforced concrete slabs were tested under two vertical line loads as part of the experiment.

This paper presents an exploration of choosing the optimum density for concrete that achieves the best structural performance for two-way slabs made of concrete with fine aggregate in different proportions (75%, 50%, 25%, and 0%) less than the ratio (100%) used in ordinary concrete to produce different densities (2207, 1792, 1536, 1310 kg/m³) as well as another slab made of normal concrete used as a reference slab with a density of 2414 kg/m³ to get some of the benefits of no fine concrete, as well as the ability to use it as a structural material.

2. Experimental program

The experimental program includes two stages, the first stage includes producing four concrete mixes with different ratios of fine aggregate (0%, 25%, 50% and 75%) to get a concrete of different densities (1310, 1536, 1792 and 2207 kg/m³) as well as normal concrete (100%) of (2414 kg/m³) used as a reference. The second stage includes constructing and testing five slabs, four of them made of concrete with different ratio of fine aggregate as well as another slab made of normal concrete used as a reference slab to study the structural behavior of this type of slab. All slabs have same dimension (450 mm *450 mm *450 mm) as shown in Table 1.

Table 1: Designations of the testing slabs

Slab designation	The Densities (kg/m ³)	The mix Ratio
S1 Sand 100% (Normal)	2414	1:1.5:3
S2 Sand 75%	2207	1:1.125:3.375
S3 Sand 50%	1792	1:0.75:3.75
S4 Sand 25%	1536	1:0.375:4.125
S5 Sand 0%	1310	1:0:4.5

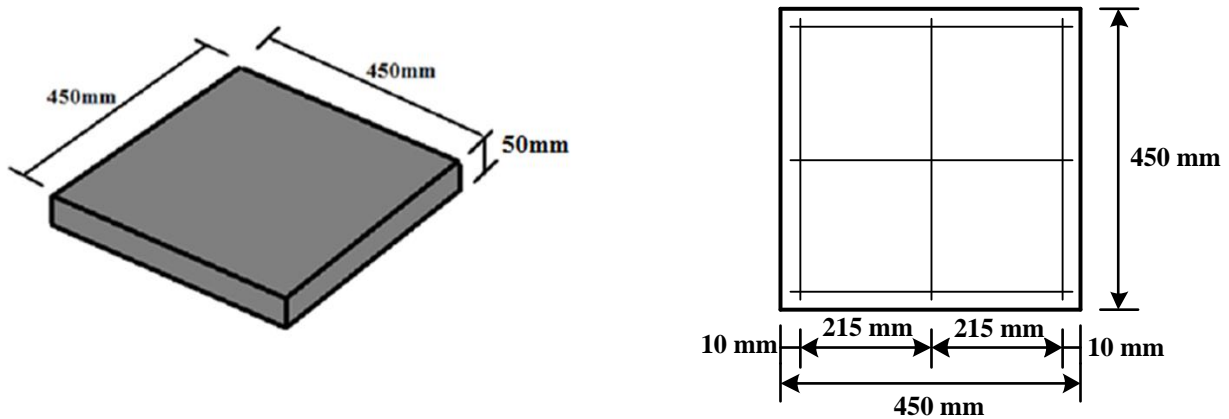

Figure 1. Slab dimensions and reinforcement details

3. Material components

3.1 Cement

The Portland cement (type I) from Tasluja Factory was used in this study. Test results indicated that the properties of this cement conform to the requirements of Iraqi Standard Specification I.Q.S. No.5, 1984 [14].

3.2 Fine aggregate

Natural sand from the Assidour region have been used as the fine aggregate in this work. Before using it, the Material Laboratory at Diyala University's Engineering College conducts a sieve examination to guarantee its suitability for mixing. According to this analysis, the fineness modulus is 2.78. The sand sieve analytical results and the Iraqi Specification No.45/1984 [15] limitations.

3.3 Coarse aggregate

The Assidour region provides crushed gravel with a maximum size of 10 mm. The sieve is evaluated in the Material Laboratory of Diyala University's Engineering College before being used to ensure that it is suitable for mixing and determining the primary proportions of mix ingredients in compliance with Iraqi standard No.45/1984 [15].

3.4 Steel reinforcement

The main steel reinforcement bars were deformed 10 mm diameter of 451 MPa yield stress was used to form the flexural reinforcement of all the slabs. According to (ASTM A616/A 615M, 2000) [16]. Figure (2) the illustration depicts one of the slab reinforcements employed in this research.



Figure 2. The steel reinforced used in the study

3.5 Water

The concrete was mixed with clean tap water.

3.6 Concrete mix proportions

The mixes design according to ACI 213 Guide [17]. Figure (3) shows the compressive strengths of no fine concrete. Table (2) shows the materials proportions for each blend as well as the compressive strength of the models.



Figure 3. The cube's compressive strengths (no fine concrete)

Table 2: Material quantity per cubic meter and compressive strength

Slabs	Cement (Kg)	Water (Liter)	Sand (Kg)	Gravel (Kg)	Compressive strength (fc) MPa
S1	4	2.7	6.2	12.78	31
S2	4	1.8	4.65	14.33	29
S3	4	1.8	3.1	15.88	25
S4	4	1.8	1.55	17.43	19.38
S5	4	1.8	0	18.98	14.45

4. Mixing

The Structural Laboratory of Engineering College at Diyala University performs the mixing and casting processes. The following is the procedure:

1. A mechanical mixer was used to combine the materials; fine and coarse aggregates were put to the mixer.
2. The cement is added to the mixer also added the water. Then, the mixture is mixed. Figure (4) shows pictures of some stages in mixing processes.



Figure 4. Stages of materials mixing process

5. Casting and curing

The major specimens are cast in molds when the mixing process is completed, and the specimens are then supplied to the vibrating table. To keep the water from evaporating, the

specimens are covered with a nylon sheet. After 24 hours, the specimens are taken from the molds and cured in a water bath for about a month, as seen below. In Figure (5) the mix is applied to the slab mold.



Figure 5. Applying the Mix in the Slab Mold

6. Testing of slabs

To make cracks more visible, the slabs were painted white. The machine used in the testing is a universal hydraulic machine with a capacity of (600kN) that is located in the Diyala University College of Engineering's Structural Engineering Laboratory as shown in Figure (6). The bottom face of the mid span was firmly

attached to a dial gauge with 0.002 mm accuracy to measure mid span deflection, as shown in Figure (7). The slabs were loaded in a single direction. To apply the load in the center of the slabs, a steel cylinder under a hydraulic jack was employed. The loads were applied in successive increments until failure was reached, and the mid span deflection was measured at each load step by.



Figure 6. Machine used to test the slabs



Figure 7. Dial gauge position

7. Discussion and result

The results of the tests have been discussed in terms of carried out in this project to study the structural behavior of two-way slabs include lightweight concrete as well as a reference slab made of conventional weight concrete. The initial crack load, ultimate load, mode failure, and load-deflection curve.

7.1 Failure mode and crack pattern

Figure (8) depicts the crack patterns at the failure of the various slab specimens. The first

crack load refers to the crack that forms in all slabs in the middle of the bottom slab face when a load is applied. Increasing the load after the first crack in the reference slab S1 caused the initial cracks to expand and extend diagonally to the corners and vertically to the top face. Decreasing the density of the slab in S2, S3, S4 and S5 made the cracks form and spread quickly and the slab failure tends towards the brittleness, and the cracks diffused and grew faster and were wider. Also, Figure (8) reveal that decreasing the weight of the slab the did not affect the failure mode as all the examined slabs failed with flexure mode.

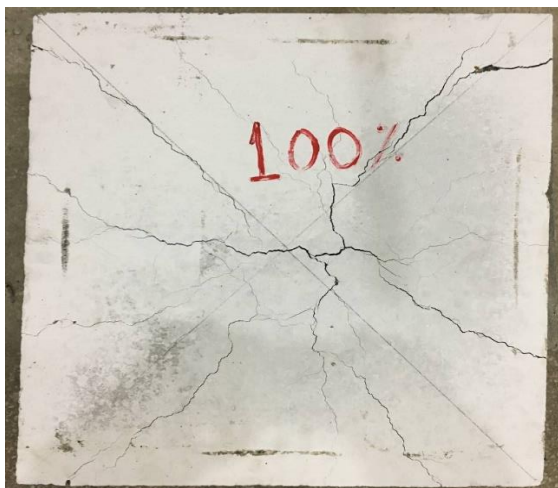

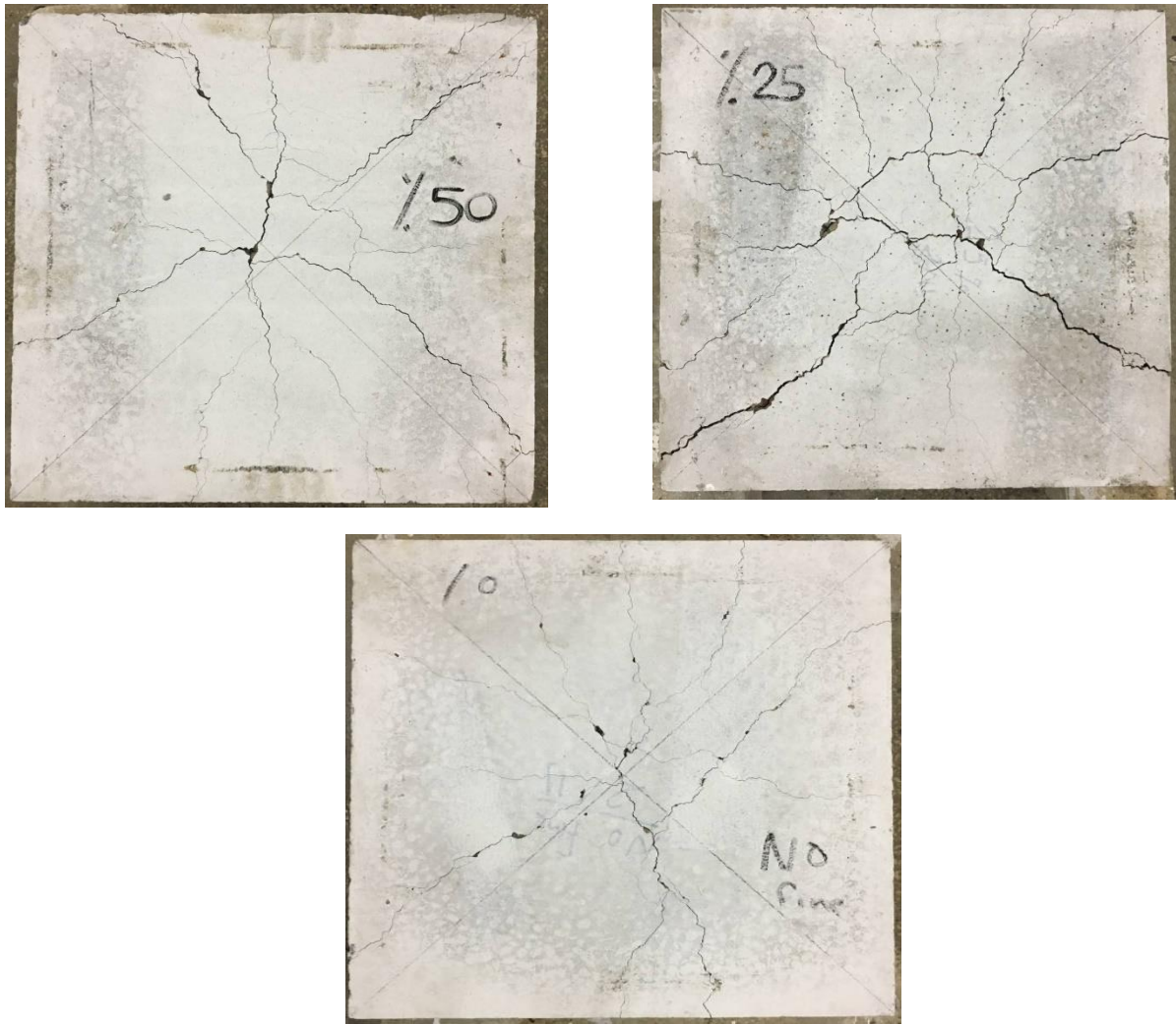

Figure 8. Crack pattern of the slabs

7.2 The ultimate load and the first crack load

Table (3) shows the first crack and ultimate load of the slabs that were tested. In fact, lowering the slab density from 2414 kg/m³ to 1310 kg/m³ by reducing fine aggregate in concrete from 100% to 0% has a bigger influence on the first crack load than the ultimate load of two-way slabs. Table (3), on the

other hand, revealed that reducing lightweight concrete from 2414 kg/m³ to 2207, 1792, 1536, and 1310 kg/m³ of the slabs S1, S2, S3, S4, and S5 by reducing fine aggregate in concrete from 100 % to 75 %, 50 %, 25 %, and 0 % reduced the first crack load by 16.7%, 33.3 %, 38.9%, and 61.1 %, respectively, and the ultimate load by 7.3 % (having 100 % of fine aggregate).

Table 3. Tests results of the tested slabs

Slab	First crack load (kN)	Decreasing percentage in first crack load (%)	Ultimate load (kN)	Decreasing Percentage in ultimate load (%)
S1	18	---	41	---
S2	15	16.7	38	7.3
S3	12	33.3	32	21.9
S4	11	38.9	22	46.3
S5	7	61.1	18	56.1

7.3 Ultimate deflection and the load deflection curve

Figure 9 depicts the load-deflection curve of the slabs that were tested. The deflection of the slabs S1, S2, S3, S4, and S5 increased in all stages of loading when fine aggregate in concrete was reduced from 100 % to 75 %, 50 %, 25 %, and 0 %, as compared to the slab S1. In addition, as demonstrated in Figure (9) and

Table (4), when the slab density lowers, the ultimate deflection decreases. When fine aggregate in concrete was reduced from 100% to 75%, 50%, 25%, and 0%, the ultimate deflection for S2, S3, and S4, and S5, respectively, was 15.1 %, 18.8 %, 12.9 %, and 13.9 %, as compared to S1. Increased voids between the cement paste and coarse aggregate cause this behavior, which leads to decreased final deflection.

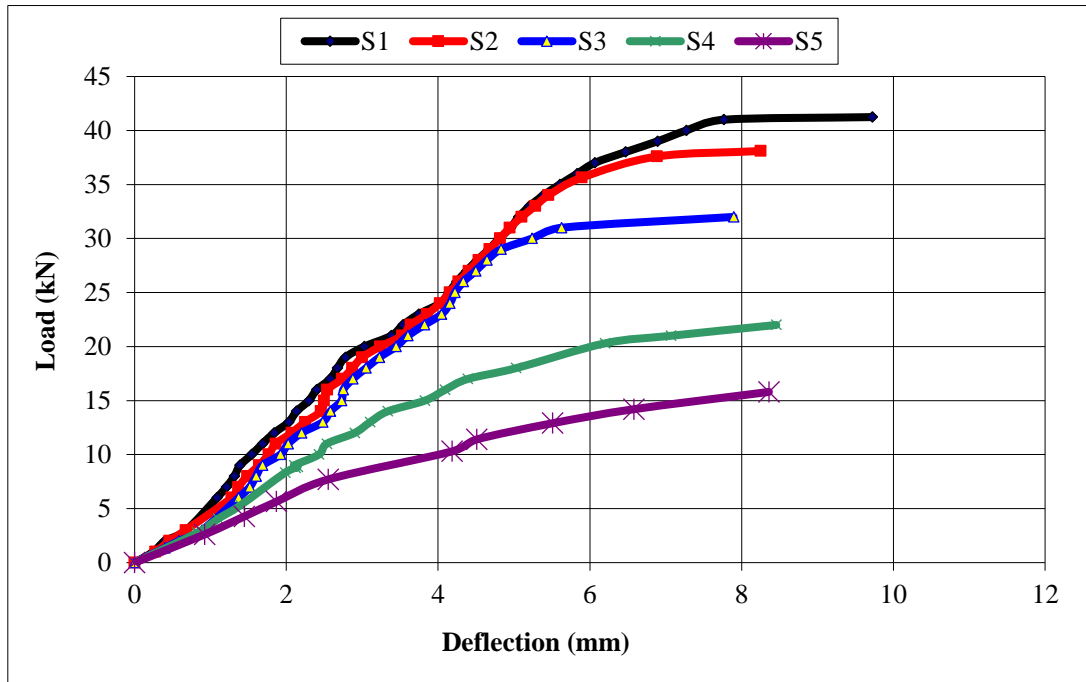

Figure 9. Load-Deflection curves of tested slabs

Table 4: Ultimate deflection of the tested slabs

Slab	Deflection at failure (mm)	Decreasing Percentage in deflection at failure (%)
S1	9.72	----
S2	8.25	15.1
S3	7.89	18.8
S4	8.46	12.9
S5	8.36	13.9

8. Conclusions

In this study, an experimental study was used to evaluate the effect of slab density as a result of mixing ratio on the structural behavior of two-way slabs. The first crack load, ultimate load, crack patterns failure manner, and load-

deflection behavior are among the results provided. It can be deduced from the results of this study's experimental effort that:

1. Decreasing the density of the slab in S2, S3, S4 and S5 made the cracks form and spread quickly and the slab failure tends

towards the brittleness, and the cracks diffused and grew faster and were wider.

2. Decreasing the weight of the slab did not affect the failure mode as all the examined slabs failed with flexure mode.
3. Reducing the slab density from 2414 kg/m³ to 1310 kg/m³ by reducing fine aggregate in concrete from 100% to 0% has a bigger impact on the first crack load than on the ultimate load in two-way slabs.
4. Decreasing the slab density from 2414 kg/m³ to 2207, 1792, 1536 and 1310 kg/m³ by reduction fine aggregate in concrete from 100% to 75%, 50%, 25 % and 0% respectively made the first crack load reduced by percentages 16.7%, 33.3%, 38.9%, and 61.1% and the ultimate load with percentages 7.3%, 21.9%, 46.3%, and 56.1%, respectively as compared to the reference (normal weight concrete slab).
5. When the slab density was reduced from 2414 kg/m³ to 2207, 1792, 1536, and 1310 kg/m³ by reducing fine aggregate in concrete from 100 % to 75 %, 50 %, 25 %, and 0 %, respectively made the deflection increase in all loading stages, as compared to the reference (normal weight concrete slab).
6. Decreasing slab density from 2414 kg/m³ to 2207, 1792, 1536 and 1310 kg/m³ by reduction fine aggregate in concrete from 100% to 75%, 50%, 25 % and 0% respectively made increased or decreased the ultimate deflection with percentage 15.1%, 18.8%, 12.9%, and 13.9% respectively as compared to the reference (normal weight concrete slab).

References

- [1] Newman, J., & Choo, B. S. (Eds.). *Advanced concrete technology 3: processes*. Elsevier, 2003.
- [2] Neville, A. M., & Brooks, J. J. *Concrete technology*, 2010.
- [3] Slaby, A.A., Aziz, K.I., & Hadeed, A.F., "Mechanical Properties of Porcelinite Reinforced Concrete Beams", *Iraqi Journal of Civil Engineering*, 10(10), 1-24, 2008.
- [4] Neville, A.M., "Properties of Concrete. Prentice Hall", Upper Saddle River, NJ, USA, 1981.
- [5] Sommerville, J., Craig, N. & Charles, A., "No-fines concrete in the UK social housing stock: 50 years on", *Structural Survey*, 29(4), PP. 294-302, 2011.
- [6] Alam, B., Javed, M., Ali, Q., Ahmad, N. & Ibrahim, M., "Mechanical properties of no-fines bloated slate aggregate concrete for construction application, experimental study", *International Journal of Civil and Structural Engineering*, 3(2), 2012.
- [7] Osman M., Marzouk H., & Helmy S., "Behavior of High-Strength Lightweight Concrete Slabs under Punching Loads", *ACI Structural Journal*, 97(3) PP. 492_498, 2000.
- [8] Abdul Rasoul Z. M. R., "Experimental Study of Punching Shear Strength of Self Compacting Concrete Slabs with Openings", *Journal of Kerbala University*, 9 (2) PP. 88-100, 2011.
- [9] YOUM, K. S.; JEON, H. K.; PARK, Y. S.; LEE, S. H.; & MOON, J., "Experimental study on punching shear of lightweight concrete slab", *The Thirteenth East Asia-Pacific Conference on Structural Engineering and Construction (EASEC-13)*, September 11- 13, Sapporo, Japan. PP. 1-7, 2013.
- [10] Abdulah M. D., "Behavior of Reinforced Lightweight Concrete Two Way Slabs Strengthened with CFRP Sheets", *Engineering and Technology Journal*, 33 (8), PP. 1813, 2015.
- [11] Zaher A.A., Abdelrahman A.A., Eldeib A. S., & Mohamed A.A., "Punching shear behavior of Lightweight foamed RC slabs", *International Journal of Application or Innovation in Engineering & Management (IJAIEM)*, 4(7) PP. 67-73, 2015.
- [12] Adil, M. A. and Abdulrazzaq, O. A., "Flexural Behavior of Composite Reinforced Concrete Slabs", *Iraqi Journal of Civil Engineering* 11(2), 55-65, 2016.
- [13] Al-Azzawi, A. A. and Abdul Al-Aziza, B. M., "Behavior of reinforced lightweight aggregate concrete hollow-core slabs", *Computers and Concrete*, 21(2)117-126, 2018.

- [14] Iraqi Specification, No. 5/1984, "*Portland Cement*", Ministry of Planning /Central Organization for Standardization and Control Quality.
- [15] Iraqi Specification, No. 45/1984, "*Aggregate from Natural Sources for Concrete and Construction*", Ministry of Planning /Central Organization for Standardization and Control Quality.
- [16] ASTM A615/615M-05a, "*Standard Specification for Deformed and Plain Carbon Structural Steel Bars for Concrete Reinforcement*", Annual Book of ASTM Standards, Vol.01.02, 2005.
- [17] ACI 213R-87, Guide for Structural Lightweight Aggregate Concrete, Detroit, Michigan, 1999.